

ROBINAIR[®]



Operating Manual for
Model 34788-H
Recovery, Recycling, Recharging Unit

SAFETY DEFINITIONS: Follow all **WARNING**, **CAUTION**, and **NOTE** messages in this manual. These messages are defined as follows: **WARNING** means you may risk serious personal injury or death; **CAUTION** means you may risk personal injury, property damage, or unit damage; and **NOTES** and **OPERATING TIPS** provide clarity and helpful information. These safety messages cover situations ROBINAIR is aware of. ROBINAIR cannot know, evaluate, and advise you as to all possible hazards. You must verify that conditions and procedures do not jeopardize your personal safety.

DISCLAIMER: Information, illustrations, and specifications contained in this manual are based on the latest information available at the time of publication. The right is reserved to make changes at any time without obligation to notify any person or organization of such revisions or changes. Further, ROBINAIR shall not be liable for errors contained herein or for incidental or consequential damages (including lost profits) in connection with the furnishing, performance, or use of this material. If necessary, obtain additional health and safety information from the appropriate government agencies and the vehicle, refrigerant, and lubricant manufacturers.

WARNINGS



ALLOW ONLY QUALIFIED PERSONNEL TO OPERATE THE UNIT. Before operating the unit, read and follow the instructions and warnings in this manual. The operator must be familiar with air conditioning and refrigeration systems, refrigerants, and the dangers of pressurized components. If the operator cannot read this manual, operating instructions and safety precautions must be read and discussed in the operator's native language.



PRESSURIZED TANK CONTAINS LIQUID REFRIGERANT. Do not overfill the internal storage vessel, because overfilling may cause explosion and personal injury or death. Do not recover refrigerants into nonrefillable containers; use only federally authorized refillable containers (DOT spec. 4BW or 4BA).



HOSES MAY CONTAIN LIQUID REFRIGERANT UNDER PRESSURE. Contact with refrigerant may cause personal injury. Wear protective equipment, including safety goggles. Disconnect hoses using extreme caution.



AVOID BREATHING A/C REFRIGERANT AND LUBRICANT VAPOR OR MIST. Exposure may irritate eyes, nose, and throat. To remove refrigerant from the A/C system, use only equipment certified for the type of refrigerant being removed.



DO NOT USE AN EXTENSION CORD. An extension cord may overheat and cause fire. If you must use an extension cord, use the shortest possible cord with a minimum size of 14 AWG.



TO REDUCE THE RISK OF FIRE, do not use the unit in the vicinity of spilled or open containers of gasoline or other flammable substances.



CAUTION—DO NOT PRESSURE TEST OR LEAK TEST EQUIPMENT AND / OR VEHICLE AIR CONDITIONING SYSTEMS WITH COMPRESSED AIR. Some mixtures of air and refrigerant have been shown to be combustible at elevated pressures. These mixtures, if ignited, may cause injury or property damage.



TO PREVENT CROSS-CONTAMINATION, USE THIS UNIT WITH R-134A REFRIGERANT ONLY. The unit is designed to recover, recycle, and recharge only R-134a refrigerant. Do not attempt to adapt the unit for another refrigerant. Do not mix refrigerant types through a system or in the same container; mixing of refrigerants will cause severe damage to the unit and the vehicle air conditioning system.



HIGH VOLTAGE ELECTRICITY INSIDE THE UNIT HAS A RISK OF ELECTRICAL SHOCK. Exposure may cause personal injury. Disconnect the power before servicing the unit.

Additional health and safety information may be obtained from the refrigerant and lubricant manufacturers.

OPERATING NOTE: At temperatures exceeding 120° F / 49° C, wait 10 minutes between recovery jobs.

Table of Contents

Introduction	2
Technical Specifications	2
Keypad Functions	3
Glossary	3
Menu Functions	4
Setup	5
Unpack the Accessory Kit	5
Power Up the Unit	5
Select a Language	5
Select Operating Units	5
Set Tank Fill Level	6
Add Oil to the Vacuum Pump	6
Fill the Internal Storage Vessel	7
Operating Instructions	8
Recover Refrigerant from a Vehicle	8
Evacuate the A/C System	9
Replenish A/C System Oil	10
Recharge the A/C System	11
Operating Instructions — Automatic	13
System Flush	15
Maintenance	18
General	17
Electrical Protection	17
Manually Fill the Internal Storage Vessel (ISV)	17
Tank Fill Hose Filter Service	18
Replace the Filter-Drier	19
Adjust Tank Fill Level	20
Change Vacuum Pump Oil	21
Scale Calibration Check	22
Check for Leaks	22
Replacement Parts	23
Spanish Manual	25
French Manual	49
Safety Precautions	Inside Front Cover
Warranty	Inside Back Cover

IMPORTANT: To comply with federal law governing A/C system service, you must complete and mail the MVAC Certification Form included in the accessory kit. Technicians using this equipment must be certified under EPA Section 609 (Environmental Protection Agency). For more information, read the MACS information included in the accessory kit, or visit the MACS website at www.macsw.org.

To validate the warranty provided by Robinair, complete the warranty card included in the accessory kit, and mail it within ten days from the purchase date of the unit.

Introduction

Robinair No. 34788-H is used on R-134a vehicles and is designed to be compatible with existing service equipment and standard service procedures. This unit is a UL-listed, single-pass system that meets SAE specifications for recycled refrigerant. Follow the SAE-J2211 recommended service procedure for the containment of R-134a.

The unit includes a 1.5 cfm (42 l/m) Robinair high vacuum pump for fast, thorough evacuation. The compressor pulls the A/C system to 0 psig, then works in series with the vacuum pump to achieve highly efficient recovery and immediate recharge. If the system is not opened for service, there is no need to pull additional vacuum. If the system is opened for service, use the unit's vacuum cycle to remove air and moisture from the A/C system. (We recommend a minimum 15-minute vacuum, or follow the vehicle manufacturer's specs.) *Note: R-134a systems require special oils. Refer to the A/C system manufacturer's service manual for oil specifications.*

Control Panel: folds flat for storage.

Flow Indicators: red light indicates high-side flow from vehicle A/C system through unit; blue light indicates low-side flow from vehicle A/C system through unit.

Manifold Gauges: connect to vehicle A/C system; show system's low-side and high-side pressure.

Digital Display: visual interface between operator and machine.

Tool Storage Areas (additional storage on back side for extra filter-driers and oil bottles).

Main Power Switch: supplies electrical power to unit.



Technical Specifications

Voltage 115V, 60 Hz
Operating Range . . 50° to 120° F (11° to 49° C)
Filter-Drier 43 cu. in. spin-on type

Pump Free-Air Displacement . . 1.5 cfm (42 l/m)
Dimensions 49" H x 34" W x 23" D
 (124.5 cm x 86.4 cm x 58.4 cm)

Keypad Functions



START / YES begins or resumes a function, or answers a query.



STOP / NO terminates or pauses a function, or answers a query.



MENU displays the selection menu.

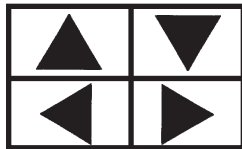

ARROWS are used for scrolling through menu items.



AUTOMATIC activates a menu that helps the user set up an automatic recover / vacuum / leak test / charge sequence.



RECOVER activates the recovery sequence.



VACUUM activates the vacuum sequence, followed by an option to activate a leak test.



INJECT OIL – not applicable to this unit.



CHARGE charges the vehicle A/C system with a programmed amount of refrigerant.



REFRIGERANT DATABASE (optional) offers access to system oil and refrigerant specifications by vehicle model and year. Purchase Robinair No. 34411.

When the unit is not performing a function, pressing the **UP** or **DOWN** arrow key adjusts contrast on the digital display.

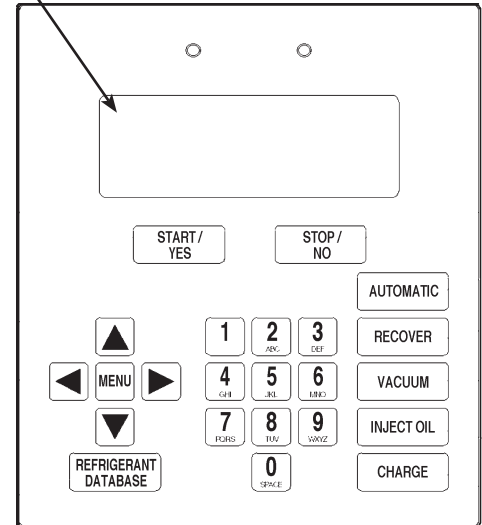

Keypad

Glossary

A/C System : The vehicle air conditioning system being serviced.

Internal Storage Vessel : The refillable refrigerant storage vessel designed specifically for this unit; 30 lb. (14 kg).

Source Tank : A disposable tank of new refrigerant used to refill the internal storage vessel; not included.

Unit : Model No. 34788-H.

Introduction

Menu Functions

1. Press the **MENU** button on the keypad.
2. Press the **UP** or **DOWN** arrow key to scroll through the menu choices shown on the second line of the display :
SELECT LANGUAGE
VERSION X.XX
SELECT UNITS
MAINTAIN VACUUM OIL
MAINTAIN FILTER
REFRIG MANAGEMENT
MANUAL REFILL
ADJUST TANK FILL LVL
CALIBRATION CHECK
SELECT BEEPER TONE
SERVICE MENU
HOSE FLUSH
DISPLAY TANK INFO
SYSTEM FLUSH
3. Press **START / YES** to make a choice from the menu. Press **STOP / NO** to pause during any process, and **STOP / NO** a second time to exit a process.

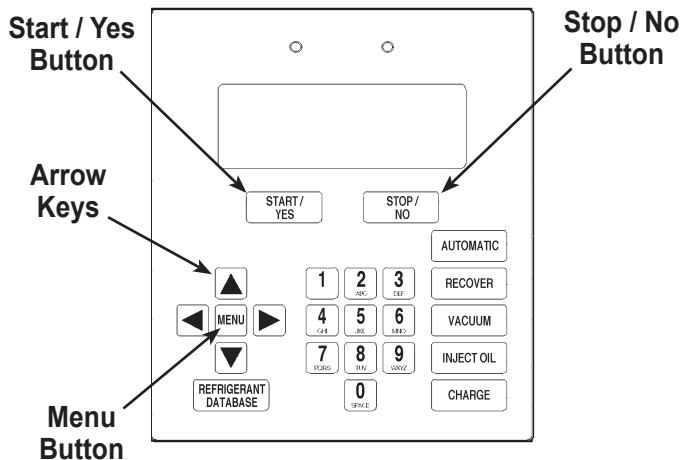

Select Language

Operator may choose to have prompts displayed in one of three languages: English, Spanish, or French.

Version X.XX

Displays the revision level of the software in the unit.

Select Units

The operator may choose to have test results displayed in Imperial (lb.), Imperial (lb. and oz.), or Metric (kg).

Maintain Vacuum Oil

For maximum vacuum pump performance, change vacuum pump oil after every 10 hours of operation. This menu item

displays how long the vacuum pump has operated since the last oil change, and allows the user to reset the value once an oil change is complete. Refer to the instructions outlined in the Maintenance section under *Change Vacuum Pump Oil*.

Maintain Filter

The filter-drier removes acid, particulates, and moisture from the refrigerant. To meet SAE J-2788 requirements, it is mandatory to replace the filter-drier after 150 lbs. (68 kg) of refrigerant has been filtered. This menu item shows how much refrigerant has been filtered since the last filter change, and allows the user to reset the value once a filter change is complete. A code, which appears on the filter, must be entered into the unit to ensure compliance with SAE J-2788. Refer to instructions outlined in the Maintenance section under *Replace the Filter-Drier*.

Refrig Management

Displays the amount of refrigerant recovered, charged, and replenished (for the life of the unit), and filtered (since the last filter change).

Manual Refill

Use to transfer refrigerant from the source tank to the internal storage vessel (ISV). Refer to instructions outlined in the Maintenance section under *Manually Fill the ISV*.

Adjust Tank Fill LVL

When connected to a refrigerant source, the unit maintains a pre-set amount of refrigerant in the internal storage vessel (default is 15 lbs.). This value may be adjusted up or down to suit the user's needs. Refer to instructions outlined in the Maintenance section under *Adjust Tank Fill Level*.

Calibration Check

Use to verify internal scale calibration. Refer to instructions in Maintenance section under *Scale Calibration Check*.

Select Beeper Tone

Select one of two tones for an alert signal, or mute the signal completely.

Service Menu

For Robinair service center use only.

Hose Flush

Flushes residual PAG oil from the unit for service of electric POE oil-based hybrid systems.

Display Tank Info

Displays internal storage vessel (ISV) pressure and temperature. Use to check the ISV for excessive pressure.

System Flush

When used with the appropriate flush adapter kit, this menu item allows the A/C system or component to be flushed with R-134a refrigerant.

Unpack the Accessory Kit

Unpack the accessory kit from the bag, and remove the plastic packaging. The kit consists of

- A calibration weight.
- Vacuum pump oil, oil filler cap, and tube.
- Plastic pouch containing a warranty card (to be completed and mailed), applicable MSDS sheets, a service center listing, and an envelope of Mobile Air Conditioning Society (MACS) information.

Important: You must complete and mail the MVAC Certification Form and your technicians must be certified with the Environmental Protection Agency (EPA) to operate this equipment.

Power Up the Unit

1. Unwind the power cord from the handle, and plug it into a correct voltage outlet. See Figure 1.
2. Turn on the main power switch. The first time the unit is powered up, it displays the initial setup mode.

Select a Language – English Seleccionar Idioma – Espanol Selection Langue – Francais

The operator may choose to have prompts displayed in one of three languages: English, Spanish, or French.

1. Use the **UP** or **DOWN** arrow key to toggle through the choices of English, Spanish, or French. Refer to Figure 2.
2. Press **START / YES** to select the displayed language.

Select Operating Units

The operator may choose to have test results displayed in Imperial (lb., or lb. and oz.) or Metric (kg) units.

1. Use the **UP** or **DOWN** arrow key to toggle through the choices of IMPERIAL UNITS or METRIC UNITS.
2. Press **START / YES** to select the displayed operating unit choice.

CAUTION: R-134a systems have special fittings (per SAE specifications) to avoid cross-contamination with R-12 systems. DO NOT adapt your unit for a different refrigerant — system failure will result.

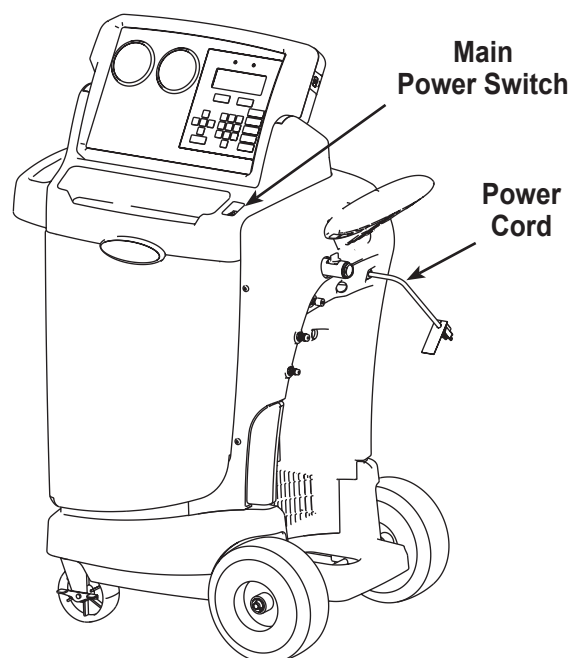

Figure 1

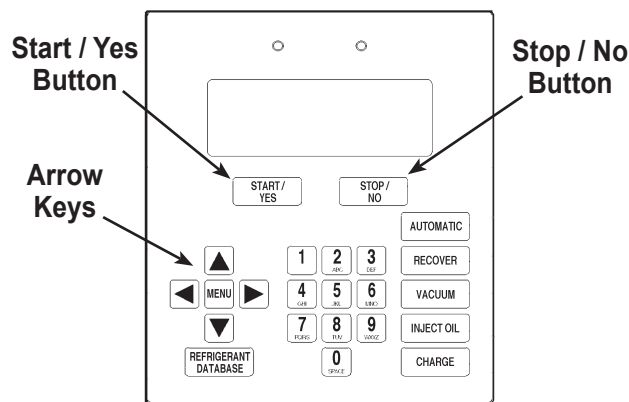

Figure 2

Setup

Set Tank Fill Level

The operator may either accept the unit's pre-set default weight of 15 lbs. (6.8 kg) of refrigerant stored in the internal storage vessel (ISV), or change the amount to accommodate the application.

The unit displays

LEVEL: 15.00 LBS.
ENTER TANK FILL LVL
LIMIT: 4 TO 17 LBS.
PRESS START / YES TO SAVE

1. Press **START / YES** to accept the default amount, or use the keypad to enter a desired amount and press **START / YES**.

Add Oil to the Vacuum Pump

CAUTION: The vacuum pump is shipped without oil in the reservoir. Failure to add oil to the vacuum pump will damage the pump.

The unit displays

ADD 5 OZ OF NEW OIL
TO VACUUM PUMP
START TO CONTINUE

1. Remove the brass plug from the vacuum pump oil fill port. See Figure 3.
2. Attach the flexible tube/cap to the oil bottle; **pour only five (5) ounces** of vacuum pump oil into the fill port. *Note: You will top off the oil in the next step as the vacuum pump is running.*
3. Press and release the **START / YES** key. While the vacuum pump is running, slowly add oil until the level rises to the center of the reservoir's sight glass.
4. Press the **STOP / NO** key to stop the vacuum pump, and install the brass plug in the fill port.
5. Press **START / YES** to continue.

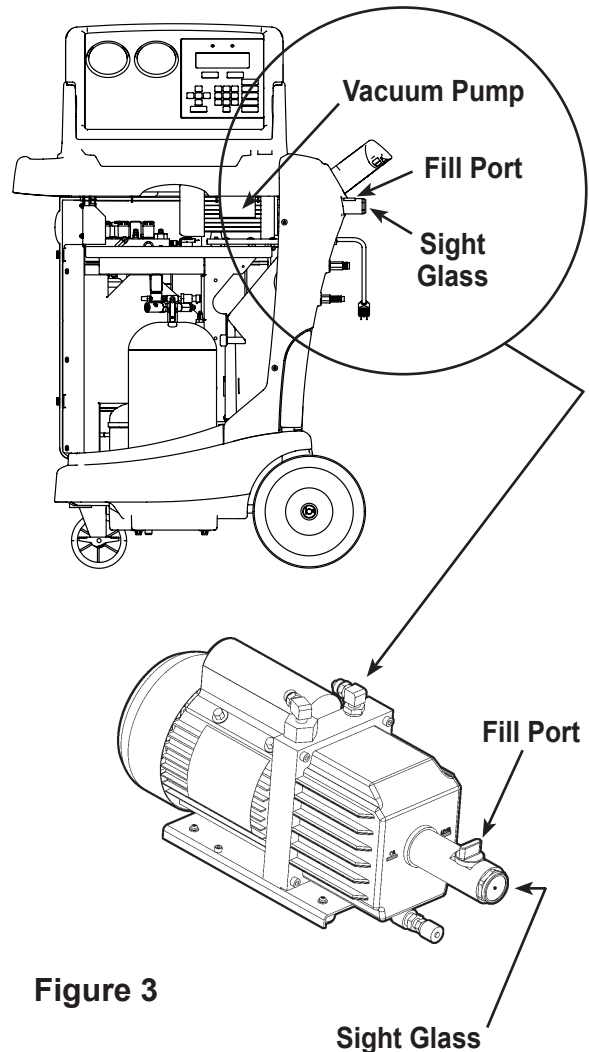

Figure 3

⚠ CAUTION: The unit is programmed to run the setup procedure as outlined here. To prevent personal injury, do NOT operate the unit at any other time without the brass plug installed, because the vacuum pump is pressurized during normal operation.

Fill the Internal Storage Vessel (ISV)

1. Press **START / YES**, and the unit automatically runs a 5-minute vacuum to clear all internal air.

Note: The “burping” noise heard during this process indicates air is being purged from the system—this is normal.

2. After the vacuum pump shuts off, connect the fill hose to the liquid connector on a full source tank.
3. Open the source tank valve.
4. Install the source tank, and secure it to the unit (using the tank strap) in such a way that liquid refrigerant is supplied to the connection.
5. Press **START / YES** to begin filling the internal storage vessel. Add at least 8 lbs. (3.6 kg) of refrigerant to ensure enough refrigerant is available for charging.

This process takes 15–20 minutes. The unit stops when a sufficient amount of refrigerant has been transferred to the internal tank, or when the source tank is empty.

Press **STOP / NO** to pause. Press **STOP / NO** again to exit, or **START / YES** to resume.

6. When the fill process is complete, press **STOP / NO** to exit. The unit is ready for operation.

Note: There is no need to calibrate the scale; it is calibrated at the factory.

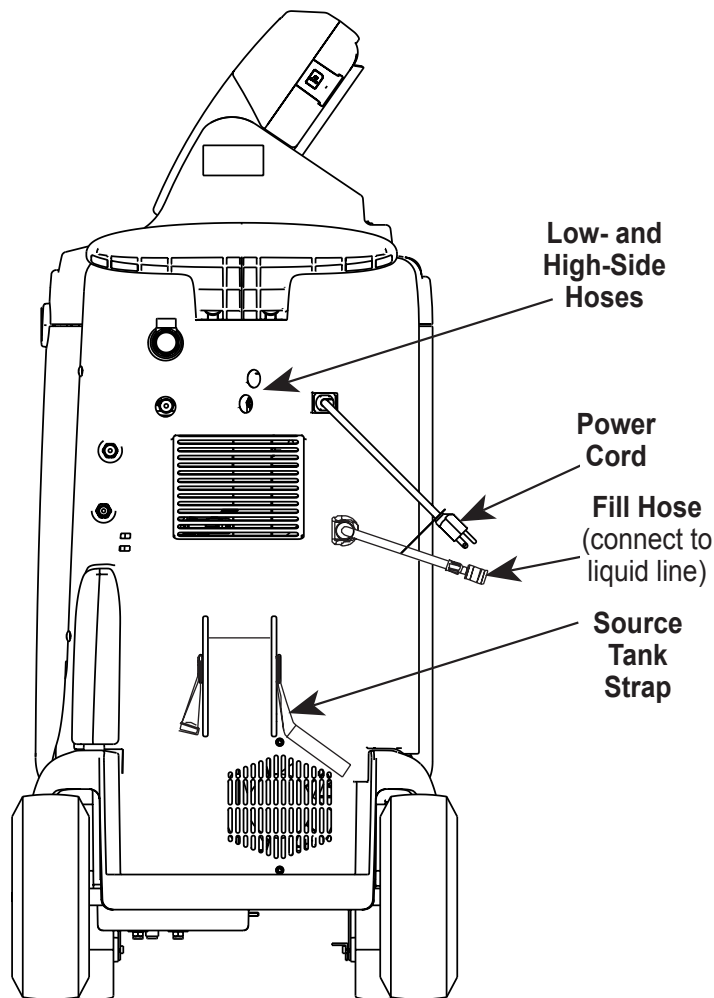

Figure 4
Side View

Operating Instructions

Recover Refrigerant from a Vehicle

1. Empty the oil drain bottle located on the right-hand side of the unit, if necessary, or make note of the current oil level. See Figure 5.
2. Connect the high- and low-side hoses to the vehicle A/C system.
3. Open the coupler valves on the hoses.
4. Press the **RECOVER** button.

Note: The clicking noise heard during the recovery process indicates the solenoid is opening and closing — this is normal.

5. When the system has recovered to 0 psi, the vacuum pump automatically starts and runs until recovery is complete. The unit then goes into an automatic oil drain—this may require up to 90 seconds to complete.
6. After the oil drain is complete, the display shows

RECOVER COMPLETE
RECOVERED XX.XX LBS. (X.XX KG)
CHECK OIL BOTTLE

Note: The displayed recovered weight can vary, depending on ambient conditions, and should not be used as an indicator of scale accuracy.

7. Check the oil drain bottle, and note the amount of oil that was removed from the A/C system. This is the amount of new oil that must be charged into the A/C system after the service is complete.
- Use only **new** oil to replace the oil removed during the recycling process.
 - Dispose of used oil according to local, state, and federal regulations.

Recovery is complete. You are now ready to either advance to the charge process, or to make repairs to the A/C system followed by the evacuation process.

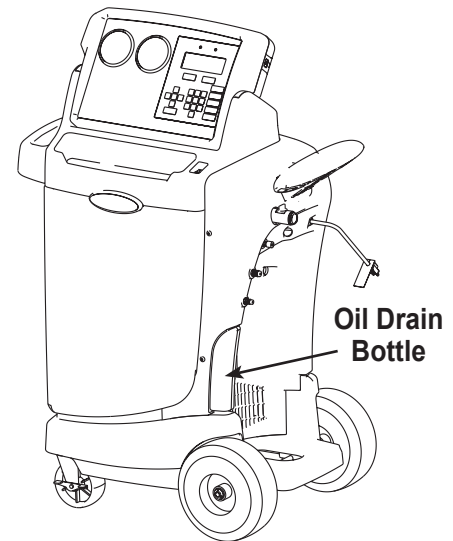

Figure 5

Operating Tips

After the **RECOVER** function is selected :

- If system pressure is below 10 psi, the display reads
LOW RECOVER PRESSURE
CHECK CONNECTIONS
*until pressure increases, or the **START / YES** button is pressed. Verify the high- and low-side hoses are connected and coupler valves are open. Press **STOP / NO** to exit.*
- If 100 lbs. (45 kg) or more of refrigerant has been recovered since the last filter-drier change, the display reads

FILTER WEIGHT XXX LB (XX KG)

To meet SAE J-2788 requirements, it is mandatory to replace the filter-drier after 150 lbs. (68 kg) of refrigerant has been filtered. The unit gives a warning to replace the filter when filter weight reaches 100 lbs.; when filter weight reaches 150 lbs., the unit locks out and ceases to operate. Refer to instructions outlined in the Maintenance section under Replace the Filter-Drier.

Evacuate the A/C System

1. Ensure service hoses are connected, and coupler valves are OPEN.
2. Press **VACUUM**.
3. Press **START / YES** to accept the default evacuation time of 10 minutes, or enter the desired vacuum time using the number keys, and press **START / YES**.

CAUTION: The unit pulls a vacuum on the vehicle A/C system to remove air and boil off moisture that may be present in the system. Evacuate the system for at least 10 minutes, or follow the A/C system manufacturer's specifications, to ensure adequate moisture and contaminant removal.

4. The unit gives you the option of doing a leak test after evacuation.
Press **START / YES** to perform the leak test.
Press **STOP / NO** to skip the leak test and begin evacuation.
5. The unit starts the vacuum pump to evacuate the A/C system and stops when the specified amount of time has elapsed.
Press **STOP / NO** to pause the process. Press **START / YES** to resume, or **STOP / NO** again to exit.

You are now ready to replenish the A/C system with new oil, if necessary, or to recharge the system with refrigerant.

Operating Tips

- *If the vacuum pump has run for 10 or more hours without an oil change, the unit displays*

VACUUM OIL TIME XX:XX
CHANGE OIL NOW?

Refer to instructions outlined in the Maintenance section under Change Vacuum Pump Oil.

- *Before the unit begins evacuating the A/C system, it checks for any pressure in the system that might damage the vacuum pump. If pressure is detected, the unit displays*

PRESSURE EXISTS
PRESS ANY KEY TO EXIT

Press any key to exit, and recover refrigerant before proceeding.

- *If a leak test was selected at the end of vacuum, and a leak is detected, the unit displays*

LEAK TEST FAILED
PRESS ANY KEY TO EXIT

Press any key to exit the evacuation, perform needed repairs, and repeat the evacuation.

- *To ensure an accurate leak test, it is imperative that a thorough recovery and evacuation of the system be performed. During the recovery process, cold spots can develop in the automotive system. Pockets of refrigerant in desiccant and in system oil will continue to vaporize as the A/C system temperature equalizes toward ambient. As this occurs, A/C system pressure will increase, which may be interpreted by the unit as a leak.*

This will vary somewhat with ambient temperature conditions.

Operating Instructions

Replenish A/C System Oil

Oil may be replenished after the charge cycle by using an oil inject tool. Use separate oil inject tools for PAG and POE systems to prevent oil cross-contamination.

CAUTION : To prevent damage to equipment,

- Use only **NEW** oil to replace the oil removed during the recycling process.
 - Charge only the amount of oil that was removed from the A/C system during the recovery process. If no oil was removed from the A/C system during recovery, **DO NOT** charge any oil into the A/C system.
-

Empty the oil drain bottle before recovering an A/C system to prevent an inaccurate oil charge.

1. Refer to the vehicle service manual to determine the correct oil for the A/C system being serviced.
2. Check the oil drain bottle to determine the amount of oil that was removed. See Figure 6.
3. Follow instructions included with your oil inject tool.

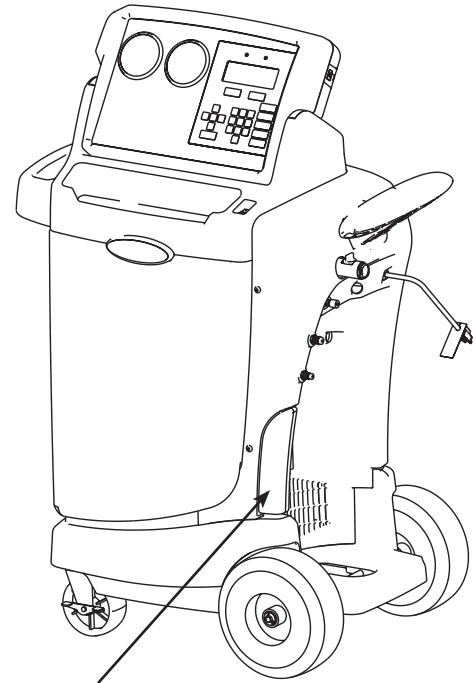

Oil Drain Bottle

Figure 6

Operating Instructions

Recharge the A/C System

If you are servicing a hybrid vehicle having an electric compressor with POE oil, first perform a brief hose flush procedure to clear the unit of residual PAG oil. **CAUTION: Failure to perform this procedure will cause contamination of the hybrid system as well as failure of the compressor.**

1. Press **CHARGE**. The unit displays
CHARGE HYBRID W/ AN
ELECTRIC COMPRESSOR
THAT USES POE OIL?
YES NO

If servicing a hybrid, press **START / YES**.

Connect service couplers to the storage port connections at the rear of the unit (see Figure 7), and open the coupler valves. Press **START / YES** again to begin a hose flush procedure. When hose flushing is complete, connect the service hoses to the vehicle service ports, and press **START / YES** to continue.

2. Press **CHARGE** again to toggle between a high-side charge, a low-side charge, or both. *Note: The blue light on the control panel indicates a low-side charge; the red light indicates a high-side charge. See Figure 8.*
3. Accept the default weight by pressing **START / YES**, or type in a weight using the number keys, and press **START / YES**.
4. After a valid charge weight is entered, the display reads

CHARGE IN PROGRESS / DO NOT DISTURB
X.XX LBS. (X.XX KG)

Moving or bumping the unit at this point may result in an incorrect reading.

Note:

- *During a charge cycle, if the unit fails to transfer refrigerant due to low tank pressure, the charge process is automatically interrupted and the unit operates in a mode to build tank pressure. Once tank pressure is sufficient, the unit automatically completes the charge.*

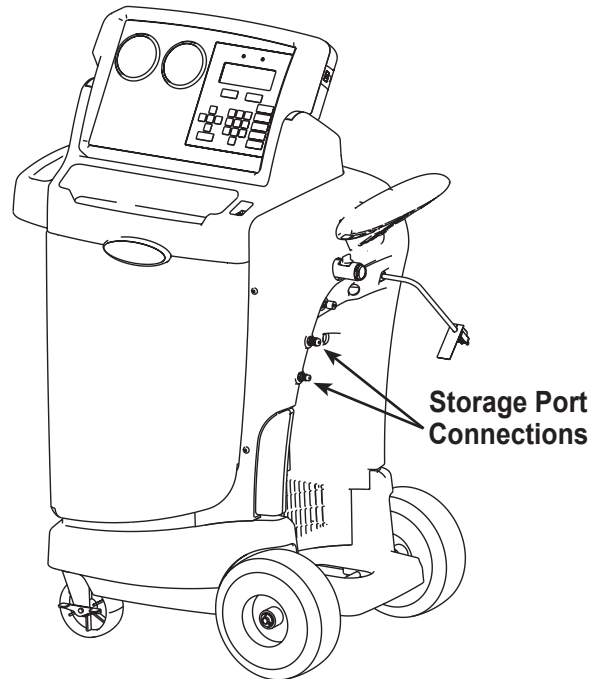

Figure 7

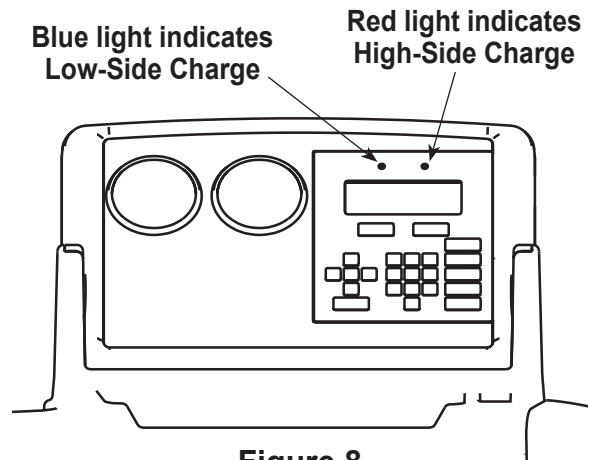

Figure 8

Operating Tips

After selecting the **CHARGE** function and entering a desired weight, if the weight entered will leave less than 2 lbs. (.91 kg) of refrigerant in the internal tank after charge, the charge function will not start. The display reads

INSUFFICIENT REFRIG.
PRESS ANY KEY TO EXIT

Refer to the Maintenance section of this manual for instructions to Manually Refill the Internal Storage Vessel (ISV).

Operating Instructions

Recharge the A/C System contd.

- *When the charge cycle gets close to the weight entered in Step 3, the unit slows down. It will charge, settle, charge again, settle, etc., with the blue/red lights illuminating accordingly.*

5. When the charge is complete, the display reads

CHARGED XX.XX LBS
DISCONNECT HS HOSE
DISCONNECT LS HOSE
START TO CONTINUE

Remove the service hoses from the vehicle A/C system.

IMPORTANT: If the low-side or high-side coupler valves are left open, the system will pull the refrigerant back out of the vehicle.

6. Press **START / YES** to begin clearing the hoses.

CLEARING HOSES
PLEASE WAIT

When the hoses are cleared, the display reads

CHARGE COMPLETE
CHARGED XX.XX LBS
ANY KEY EXITS

The A/C system is now ready for use.

Operating Instructions – Automatic

The automatic function allows a user to program an automatic recovery, vacuum, leak test, and / or charge sequence. The user may choose to skip any step in the automatic operation during the programming. A total automatic sequence may take an hour to complete.

Note: Oil recovered during the recovery cycle can be manually injected by the user before or after the charge cycle using a separate oil inject tool.

1. Connect the high- and low-side service hoses to the A/C system, and open the coupler valves on the hoses.
2. Press the **AUTOMATIC** button. See Figure 9.
3. The unit asks if a recovery is needed. Press **STOP / NO** to skip the recovery cycle; press **START / YES** to accept. If **NO** is selected, the unit asks for vacuum and time of vacuum.
4. The unit asks if a leak test is needed. Press **STOP / NO** to skip the leak test; press **START / YES** to accept.
5. The unit asks if a charge is needed. Press **STOP / NO** to skip the charge cycle and proceed to Step 6; press **START / YES** to accept.

If **START / YES** is pressed, the unit displays

CHARGE HYBRID W/ AN
ELECTRIC COMPRESSOR
THAT USES POE OIL?
YES NO

If servicing a hybrid, press **START / YES**.

Connect service couplers to the storage port connections shown in Figure 10, and open the coupler valves. Press **START / YES** again to begin a hose flush procedure. When hose flushing is complete, connect the service hoses to the vehicle service ports, and press **START / YES** to continue. Press **CHARGE** again to toggle between high- or low-side charge, or both.

Accept the default weight by pressing **START / YES**, or type in a desired weight using the number keys and press **START / YES**.

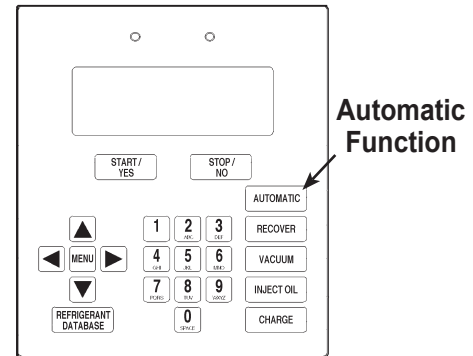

Figure 9

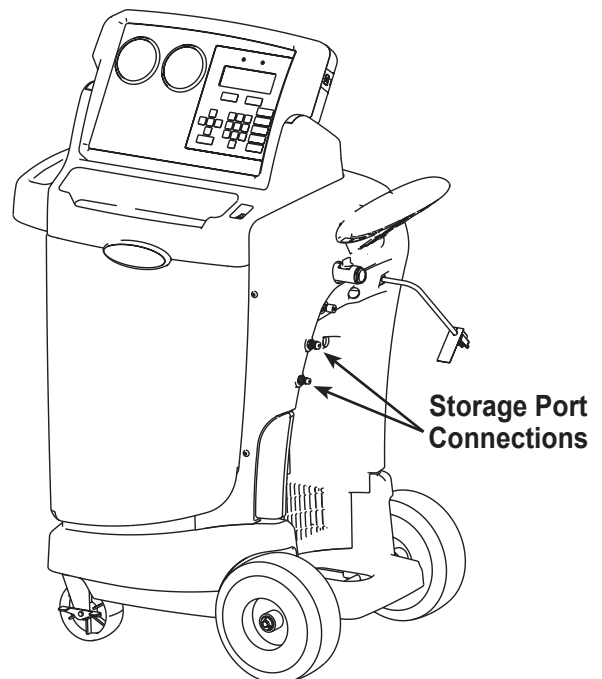

Figure 10

Operating Instructions – Automatic

6. The display shows an overview of all the tests that were selected. Press **START / YES** to begin the automatic sequence.
7. When the sequence is complete, the display shows the amount of refrigerant that was recovered and charged.
8. Close the high- and low-side coupler valves, and remove the service hoses from the A/C system. Press **START / YES** to clear hoses.

Operating Tips

- *If the weight entered is more than the refrigerant available in the internal tank, the charge function will not start. The display reads*

**INSUFFICIENT REFRIG.
PRESS ANY KEY TO EXIT**

Refer to the Maintenance section of this manual for instructions to Manually Fill the ISV.

- *If problems are encountered during the automatic sequence, the unit will “beep” three times and the control panel readout will pinpoint the problem encountered. The sequence remains paused until the user enters a decision regarding how to proceed.*
- *Before the unit begins evacuating the A/C system during the automatic sequence, it checks for any pressure in the system that may damage the vacuum pump. If pressure is detected, the unit displays*

**PRESSURE EXISTS
PRESS ANY KEY TO EXIT**

Press any key to exit the automatic sequence.

- *If a leak test was programmed, and a leak is detected, the unit displays*

**LEAK TEST FAILED
PRESS STOP TO EXIT
PRESS START TO CONTINUE**

*Press **STOP** to exit the automatic sequence and perform needed repairs. Press **START** to continue the automatic sequence despite the failed leak test.*

- *To ensure an accurate leak test, it is imperative that a thorough recovery and evacuation of the system is performed. During the recovery process, cold spots can develop in the automotive system. Pockets of refrigerant in desiccant and in system oil will continue to vaporize as the A/C system temperature equalizes toward ambient. As this occurs, A/C system pressure increases, which may be interpreted by the unit as a leak. This varies somewhat with ambient temperature conditions.*

System Flushing Process

This unit provides a method of removing oil by forcing liquid refrigerant through an A/C system, or components of an A/C system. A special flushing adapter, which is available as an accessory, accesses the A/C system at the compressor block. After flushing, the refrigerant is recovered by the unit and filtered by the recycling circuit, returning it to SAE purity levels.

A/C systems vary and may require the adapting and flushing of individual components. The following procedure works with an orifice tube system. Refer to any service bulletins as needed during this procedure.

Notes:

- *The unit must have at least 10 lbs. of refrigerant available in the ISV (as indicated on the display) for charging.*
- *If the flush process is interrupted by an accidental power-down or other fault, use the Recover mode to remove the refrigerant from the vehicle.*

Setup

1. Verify the oil drain bottle on the side of the unit is empty. See Figure 11. Recover refrigerant as outlined in this manual under *Recover Refrigerant from a Vehicle*.
2. Close service coupler valves and disconnect hoses from vehicle access ports.
3. Close the valve on the external source tank.

Note: During this procedure, up to 12 lbs. of refrigerant is charged into the vehicle A/C system. If the flushing cycle is stopped before it is complete and the external source valve is open, the unit automatically adds refrigerant to the ISV. There will be no room to recover the refrigerant used for flushing.

4. Remove the A/C system orifice tube, and reconnect the fittings to create a bypass.
5. Disconnect the compressor block at the rear of the compressor.
6. Attach the compressor block adapter (from the flushing kit) to the system side of the compressor block.
7. Configure the block connectors to provide forward- or back-flushing of the refrigerant, which flows from the unit through the red high-side connection hose. Open the red service coupler.
8. Connect the filter housing to the desired return side of the adapter block and to the blue low-side hose. Open the blue service coupler.

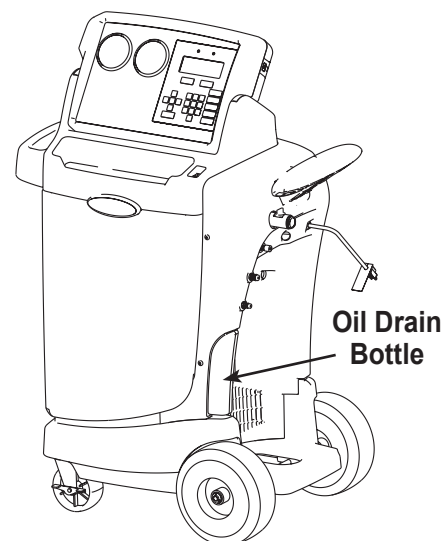

Figure 11

System Flush

9. Verify that a flushing filter is correctly installed in the flushing filter housing. Open the isolation valve on the hose.

Operating Instructions

1. Press the **MENU** button on the keypad.
2. Press the **UP** or **DOWN** arrow key to scroll through the menu choices until SYSTEM FLUSH is displayed. Press **START / YES**.
3. Press **START / YES** to accept the default flush time of 10 minutes, or enter the desired flush time using the number keys. Press **START / YES**.
4. The unit automatically runs the vacuum pump for five minutes to remove air from the A/C system.
5. The unit flushes the system for the designated length of time, and then enters a recovery mode. *Note: If the external flushing filter gets plugged, the unit displays*

FLUSH FILTER BLOCKED
RETRY?

*Press **START / YES** to retry. Press **STOP / NO** to end the flush process and recover the refrigerant. With the refrigerant recovered, the filter can be serviced and the process repeated.*

The message repeats until the filter is replaced.

6. Oil that has been collected drains into the graduated oil drain bottle. Remove the bottle and measure the oil.

Dispose of oil according to the laws in your jurisdiction. It is the responsibility of the user to determine if a material is a hazardous waste at the time of disposal.
7. When the unit displays FLUSHING COMPLETE, close service couplers, remove hoses, and reassemble the vehicle's A/C system to its original state.
8. Open the valve on the source tank.
9. Evacuate and recharge the vehicle according to the instructions in this manual.

 **WARNING: Do NOT disconnect service couplers during the flushing process. Refrigerant would spray out of the fittings, and exposure may cause personal injury.**

CAUTION: To prevent vehicle damage, use a separate oil inject tool to replace the system oil. Flushing removes all oil from the system except what remains in the compressor.

General Maintenance

1. On a regular basis, wipe off the unit using a clean cloth to remove grease and dirt.
2. Periodically check internal components for leaks; over time, fittings can loosen as the unit is moved. Open the door panel, and trace lines using a leak detector. Check connections on the back of the unit. Tighten any loose fittings or connections you may find.

Electrical Protection

The unit is equipped with a 15 amp circuit breaker on the back panel. See Figure 12. If the breaker trips, its button will pop out. A tripped circuit breaker will cause the unit to lose all power.

Press the circuit breaker button to reset.

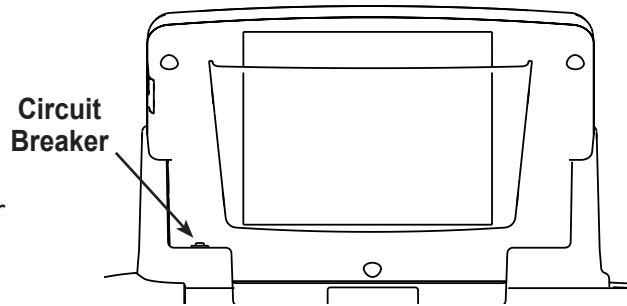

Figure 12
Back View

Manually Fill the Internal Storage Vessel (ISV)

This menu item is used to transfer refrigerant from a source tank to the internal storage vessel.

Note: If a refrigerant source tank remains connected to the unit during normal operation, the correct amount of refrigerant will be automatically maintained in the ISV. The ISV may be manually refilled, if necessary.

1. Press **Menu**, and use arrow keys to select **MANUAL REFILL**. Press **START / YES**. The unit displays

CONNECT SOURCE TANK
START TO BEGIN

2. Connect the fill hose to a full source tank, and open the source tank valve.
3. Install the source tank, and secure it to the unit with the source tank strap in such a way that liquid refrigerant is supplied to the connection.
4. Press **START / YES** to begin. The display shows

TANK FILL IN PROGRESS
TRANSFER XX LBS

5. The unit automatically stops when the preset tank fill level is reached, or press **STOP / NO** to exit.

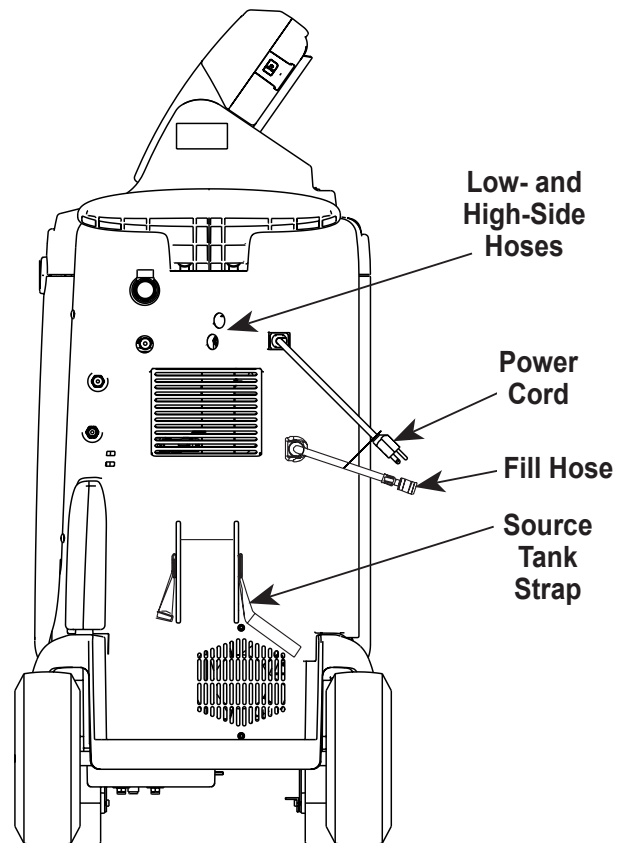

Figure 13
Side View

Maintenance

Tank Fill Hose Filter Service

The black tank fill hose at the rear of the machine contains a filter that can be cleaned when it appears that refrigerant flow is restricted.

When the machine senses low flow, it may display the following message:

- SOURCE TANK EMPTY, but yet you know the source tank contains refrigerant, connections are secure, and the source tank valve is open.

The cause may be that the tank fill hose filter is plugged.

Cleaning the Tank Fill Hose Filter

1. First ensure that pressure does not exist in the line. Disconnect the external source tank, and perform a manual tank fill to capture any refrigerant in the line.
2. Slowly and carefully disconnect the tank fill hose from the adapter. There may still be a little pressure in the line.
3. Disassemble the tank fill hose at the filter housing as shown in Figure 14.
4. Remove and clean the filter.
5. After the filter has been installed back into the filter housing, torque the housing assembly to 8.5 N•m (6 ft. lbs.).

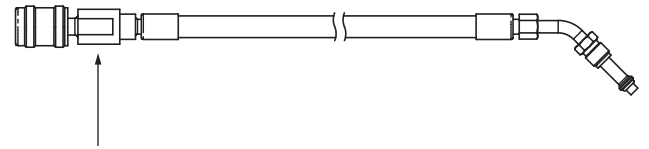

**Disassemble the
Filter Housing**

Figure 14

Replace the Filter-Drier

The filter-drier is designed to trap acid and particulates, and to remove water from refrigerant. To meet the SAE J-2788 mandate for adequate moisture and contaminant removal, the filter-drier must be replaced after 150 lbs. (68 kg) of refrigerant has been filtered.

Therefore, you no longer have a choice—the filter-drier must be replaced. The unit gives a warning when 100 lbs. of the filter capacity has been used; **the unit locks down when the 150 lb. filter capacity has been reached and will no longer function.** For this reason, always have a spare Robinair No. 34724 filter-drier on hand.

Check Remaining Filter Capacity

1. Press **MENU**.
2. Use the arrow keys to scroll through the menu to MAINTAIN FILTER, and press **START / YES**. The unit displays

XXX LBS FILTERED
RECOVER LOCKOUT IN XXX LBS
REPLACE FILTER NOW?
PRESS STOP TO EXIT

3. Press **STOP / NO** to exit.

Change the Filter

1. Press **MENU**.
2. Use the arrow keys to scroll through the menu to MAINTAIN FILTER, and press **START / YES**. The unit displays

XXX LBS FILTERED
RECOVER LOCKOUT IN XXX LBS
REPLACE FILTER NOW?
PRESS STOP TO EXIT

3. Press **START / YES** to proceed.
4. If there is pressure in the filter, the unit begins a clearing process. When complete, the display reads ENTER 10 DIGIT SERIAL NUMBER. Use the keypad to enter the serial number that appears on the new filter-drier, and press **START / YES**.

Note: If the display shows SERIAL NUMBER ERROR, the serial number is invalid or the filter-drier has already been used in this unit.

IMPORTANT: Use only authentic Robinair No. 34724 filter-driers in this machine. All performance tests and claims are based on using this specific filter-drier.

And only the Robinair No. 34724 filter-drier includes the code necessary to make the unit operable again.

Operating Tips

Enter the Serial No. for a New Filter-Drier
The numerical keys on the keypad include an alphabet that is used to enter the serial number code for the new filter-drier. The procedure is similar to text messaging. For example,

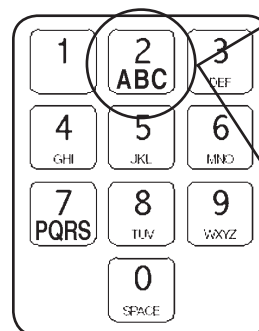

To enter an “A”:

Press the **2** key once to see the “**2**” on the digital display; press the **2** key again to display the “**A**”.

To enter a “C”:

Press the **2** key once to see the “**2**” on the digital display; press the **2** key three more times to see the “**C**” on the display.

After the appropriate letter is shown on the display, pause for a moment until the cursor moves to the next position.

Maintenance

Replace the Filter-Drier contd.

5. The display reads PLEASE REPLACE FILTER. Open the rear door of the unit and unscrew the old filter. See Figure 15.
6. Look at the new filter—verify both o-rings are lubricated and correctly located in the grooves. See Figure 16. Thread the new filter into place. Press **START / YES**.
7. Close the door. Press **STOP / NO** to exit. The filter-drier replacement is now complete.

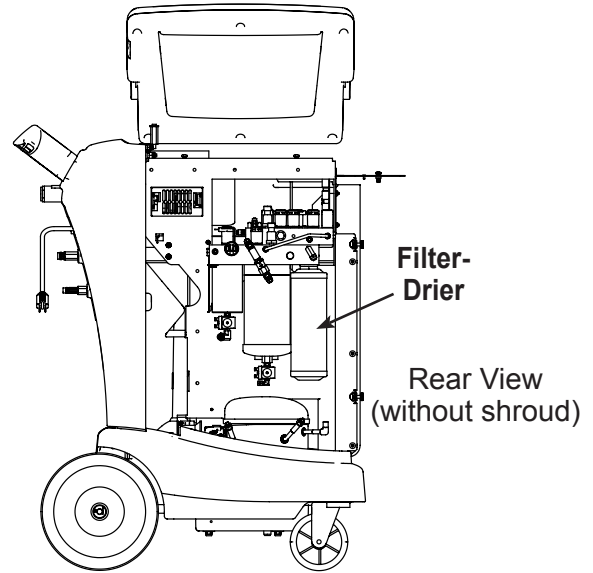

Figure 15

Adjust Tank Fill Level

When connected to a refrigerant source, the unit maintains a default value of 15 lbs. of refrigerant in the internal storage vessel. This value may be adjusted up or down to suit the application.

1. Press **MENU**.
2. Use the arrow keys to scroll through the menu to **ADJUST TANK FILL LVL**, and press **START / YES**. The unit displays
LEVEL: 15.00 LBS.
ENTER TANK FILL LVL
LIMIT: 4 TO 17 LBS.
PRESS START / YES TO SAVE
3. Use the keypad to enter a value between 4 lbs. and 17 lbs., and press **START / YES**.

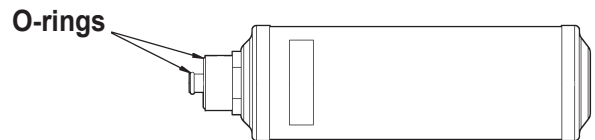

Figure 16

Change Vacuum Pump Oil

For maximum vacuum pump performance, change the vacuum pump oil after every 10 hours of operation. (The unit will display a prompt after 10 hours of operation.)

1. Press **MENU**. Use the arrow keys to select **MAINTAIN VACUUM OIL**, and press **START / YES**. The display shows how long the vacuum pump has operated since the last oil change:

PUMP OIL TIME X:XX
TIME REMAINING X:XX
CHANGE OIL?

2. Press **START / YES**. The display shows **VACUUM OIL CHANGE TIME 2:00**, and counts down to zero. Allow the vacuum pump to run until it automatically stops. The display then shows **DRAIN OLD OIL AND ADD 5 OZ NEW OIL**.
3. Refer to Figure 17, and remove the brass plug from the vacuum pump's oil fill port. (The pump drains faster when vented.)
4. Remove the oil drain fitting cap, and drain the oil into a suitable container for disposal. Replace the cap.
5. Attach the flexible tube and cap to the oil bottle; pour five (5) ounces of vacuum pump oil into the fill port.
6. Press **START / YES**. The display shows **FILL PUMP TO CENTER OF SIGHT GLASS**, and the vacuum pump starts. While the vacuum pump is running, slowly add oil until the level rises to the center of the reservoir's sight glass.
7. Press **STOP / NO**. The counter resets to zero after a vacuum pump oil change has been completed.
8. Replace the brass plug on the fill port. Press **STOP / NO** to exit to the Main Menu.

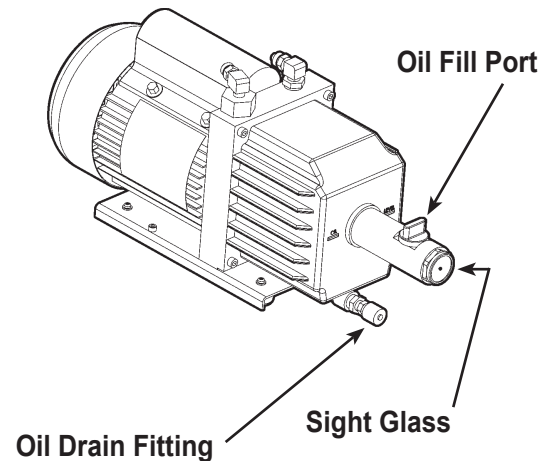

Figure 17

Review the laws in your jurisdiction to determine the correct disposal procedure for pump oil. It is the responsibility of the user to determine if a material is a hazardous waste at the time of disposal. Ensure you are in compliance with all applicable laws and regulations.

⚠ CAUTION: To prevent personal injury, do NOT operate the unit at any time without the brass plug installed, because the vacuum pump is pressurized during normal operation.

Maintenance

Scale Calibration Check

The calibration check is used to ensure that the unit's internal scale is always calibrated. During this test, use only the calibration weight that is provided with the unit.

1. Press **Menu**.
2. Use the arrow keys to scroll to CALIBRATION CHECK.
3. Refer to Figure 18, and verify the magnet on the bottom of the unit is clean. Press **START / YES**.
4. The display reads
ATTACH THE WEIGHT TO THE BOTTOM OF
THE MACHINE
PRESS START TO CONTINUE
5. Attach the weight provided to the magnet on the bottom of the unit. Press **START / YES**.
 - If the display shows CALIBRATION APPROVED, the scale is in calibration. Press any key to exit.
 - If the display shows CALIBRATION REJECT, the scale is out of calibration. Call your local service center for assistance.
 - If the display shows CALIBRATION ERROR 1, verify the calibration weight is correctly attached to the magnet, and verify the magnet is clean with nothing attached to it. If that does not correct the problem, call your local service center for assistance.

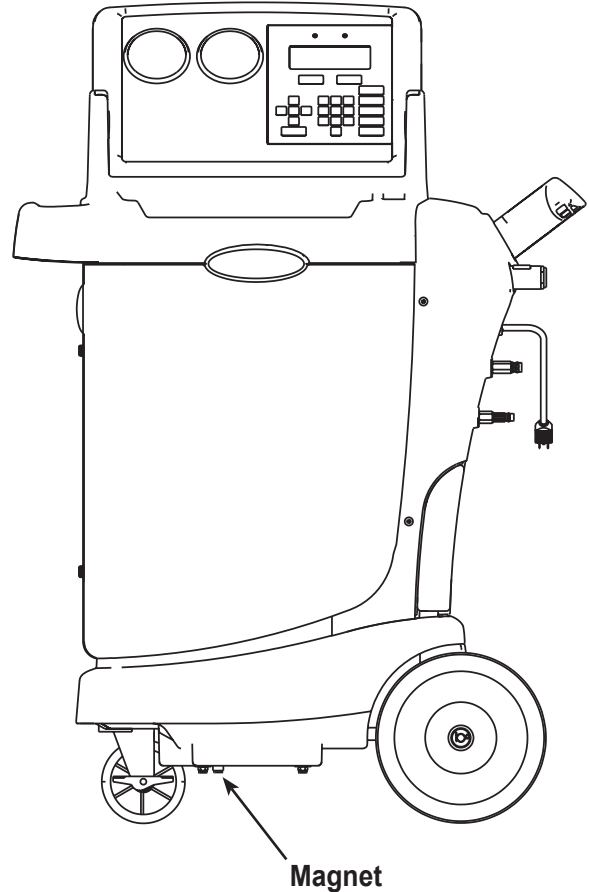

Figure 18

Check for Leaks

Check the unit for leaks every three months, or as specified by law in your jurisdiction.

1. Turn off **MAIN POWER**, and disconnect the power cord from the outlet.
2. Open the rear door; remove top cover and front panel.
3. Use a leak detector to probe all connections for refrigerant leaks. Tighten fittings if a leak is indicated.
4. Reassemble the body panels, and close the rear door.

Inspect the unit periodically for leaks. The manufacturer does not reimburse for lost refrigerant.

Replacement Parts

Component	Replacement Part No.
Filter-Drier	34724
Calibration Weight	540066
Service Coupler Set (<i>high- and low-side couplers</i>)	18192
Service Hose Set (<i>high- and low-side hoses</i>)	34722
Vacuum Pump Oil (<i>case of 12 quarts</i>)	13203
Vacuum Pump Oil (<i>case of 4 gallons</i>)	13204
Maintenance Kit	13172
Low-side Hose Flush Storage Port	546883
High-side Hose Flush Storage Port	546882
Vinyl Dust Cover (<i>optional</i>)	17492
Taehicle Database	34411
Tank Fill Hose Filter	10233

Robinair Limited Warranty Statement

Rev. November 1, 2005

This product is warranted to be free from defects in workmanship, materials, and components for a period of one year from date of purchase. All parts and labor required to repair defective products covered under the warranty will be at no charge. The following restrictions apply:

1. The limited warranty applies to the original purchaser only.
2. The warranty applies to the product in normal usage situations only, as described in the Operating Manual. The product must be serviced and maintained as specified.
3. If the product fails, it will be repaired or replaced at the option of the manufacturer.
4. Transportation charges for warranty service will be reimbursed by the factory upon verification of the warranty claim and submission of a freight bill for normal ground service. Approval from the manufacturer must be obtained prior to shipping to an authorized service center.
5. Warranty service claims are subject to authorized inspection for product defect(s).
6. The manufacturer shall not be responsible for any additional costs associated with a product failure including, but not limited to, loss of work time, loss of refrigerant, cross-contamination of refrigerant, and unauthorized shipping and/or labor charges.
7. All warranty service claims must be made within the specified warranty period. Proof-of-purchase date must be supplied to the manufacturer.
8. Use of recovery/recycling equipment with unauthorized refrigerants or sealants will void warranty.
 - Authorized refrigerants are listed on the equipment or are available through the Technical Service Department.
 - The manufacturer prohibits the use of the recovery/recycling equipment on air conditioning (A/C) systems containing leak sealants, either of a seal-swelling or aerobic nature.

This Limited Warranty does NOT apply if:

- The product, or product part, is broken by accident.
- The product is misused, tampered with, or modified.
- The product is used for recovering or recycling any substance other than the specified refrigerant type. This includes, but is not limited to, materials and chemicals used to seal leaks in A/C systems.

Declaración de garantía limitada Robinair

Revisión del 1 de noviembre de 2005

Se garantiza que este producto no posee defectos de mano de obra, materiales y componentes por el período de un año a partir de la fecha de compra. Todas las partes y mano de obra requerida para reparar los productos con defecto cubiertos bajo la garantía no tendrán costo. Aplican las siguientes restricciones:

1. La garantía limitada aplica al comprador original únicamente.
2. La garantía aplica al producto en situaciones de uso normal únicamente, como lo indica el Manual de funcionamiento. Al producto se le debe dar servicio y mantenimiento como se especifica.
3. Si falla el producto, se debe reparar o reemplazar a discreción del fabricante.
4. Los cargos de transporte de servicio de garantía serán reembolsados por la fábrica al verificar el reclamo de garantía y presentar una boleta de flete por servicio terrestre regular. Se debe obtener la aprobación del fabricante antes de hacer el envío a un centro de servicio autorizado.
5. Los reclamos de servicio de garantía están sujetos a inspección de defectos del producto.
6. El fabricante no será responsable de los costos adicionales relacionados con fallas en el producto, que incluyen pero no se limitan a, tiempo improductivo, pérdida de refrigerante, contaminación de refrigerante y envío no autorizado o cargos por mano de obra.
7. Todo reclamo de servicio de garantía se debe hacer dentro del período de garantía establecido. Se debe proporcionar la fecha de la prueba de compra al fabricante.
8. El uso de equipo de recuperación/reciclaje con refrigerantes o selladores no autorizados anula la garantía.
 - Los refrigerantes autorizados se indican en el equipo o están disponibles a través del Departamento de servicio técnico.
 - El fabricante prohíbe el uso de equipo de recuperación/reciclaje en sistemas de aire acondicionado (A/C) con fugas de sellador, ya sea porque un sello se infla o es de naturaleza aeróbica.

Esta garantía limitada NO aplica si:

- El producto, o parte de éste, se rompe accidentalmente.
- El producto se usa incorrectamente, se adultera o modifica.
- El producto se usa para recuperar o reciclar cualquier sustancia que sea diferente al tipo de refrigerante establecido. Esto incluye, pero no se limita a materiales y productos químicos utilizados para sellar fugas en sistemas de A/C.

Énoncé de la garantie limitée de Robinair

Révisée le 1er novembre 2005

Ce produit est couvert contre les défauts de matériau, de fabrication et de composant pendant un an à compter de la date d'achat. Toutes les pièces et la main-d'œuvre nécessaires aux réparations sous garantie sont sans frais. Toutefois, les restrictions suivantes s'appliquent :

1. La garantie limitée s'applique uniquement à l'acheteur initial.
2. La garantie s'applique uniquement au produit utilisé dans des conditions de fonctionnement normales conformément au manuel d'utilisation. Il doit être réparé et entretenu conformément aux spécifications.
3. Si le produit subit une défaillance, il sera réparé ou remplacé à la discrétion du fabricant.
4. Les frais de transport pour les réparations sous garantie sont remboursés par l'usine après l'évaluation de la réclamation au titre de la garantie et après la soumission d'une facture de transport terrestre standard. L'approbation du fabricant est requise avant l'expédition du produit à un atelier de réparation autorisé.
5. Les réclamations au titre de la garantie sont sujettes à l'inspection du produit défectueux par un personnel autorisé.
6. Le fabricant ne peut être tenu responsable pour tout coût supplémentaire lié à la défaillance du produit incluant, sans toutefois s'y limiter, les interruptions de fonctionnement, la perte de liquide frigorigène, la contamination des liquides frigorigènes et l'expédition et/ou les frais de main-d'œuvre soumis par des ateliers non autorisés.
7. Toute réclamation pour des réparations au titre de la garantie doit être soumise durant la période de garantie. Une preuve d'achat doit être fournie au fabricant.
8. L'utilisation d'un appareil de récupération et de recyclage avec du liquide frigorigène ou des scellants non spécifiés annule la garantie.
 - Les liquides frigorigènes autorisés sont indiqués sur l'appareil, ou ils peuvent être obtenus auprès du Service technique.
 - Le fabricant interdit l'utilisation d'un appareil de récupération et de recyclage dans les systèmes de climatisation contenant des colmatants pour fuites, que ce soient des scellants à dilatation ou aérobiques.

Cette garantie limitée NE s'applique PAS si le produit :

- ou une partie du produit a été endommagé par un accident.
- a été utilisé de façon inadéquate, ou qu'il a été altéré ou modifié.
- est utilisé pour la récupération et le recyclage de substances autres que le type de liquide frigorigène spécifié. Ces substances comprennent, sans toutefois s'y limiter, les matériaux et les produits chimiques utilisés pour colmater les fuites des systèmes de climatisation.

**Visit our web site at www.robinair.com or call our toll-free
Technical Support Line at 800-822-5561
in the continental U.S. or Canada.**

In all other locations, contact your local distributor. To help us serve you better, please be prepared to provide the model number, serial number, and date of purchase of your unit. To validate your warranty, complete the warranty card attached to the unit, and return it within ten days from date of purchase.

NATIONWIDE NETWORK OF AUTHORIZED SERVICE CENTERS

If your unit needs repair or replacement parts, contact the service center in your area. For help in locating a service center, call the toll-free technical support line or visit www.robinair.com.

**Visite nuestro sitio web en www.robinair.com o llame sin costo a
la línea de Asistencia técnica al 800-822-5561
en EE.UU. continental o Canadá.**

En todas las demás ubicaciones, comuníquese con su distribuidor local. Para ayudarnos a servirle mejor, tenga a mano el número de modelo, número de serie y fecha de compra de su unidad. Para validar la garantía, complete la tarjeta de garantía anexa a su unidad y devuélvala dentro de los diez días siguientes a la fecha de compra.

RED NACIONAL DE CENTROS DE SERVICIO AUTORIZADOS

Si su unidad necesita reparaciones o partes de reemplazo, comuníquese con el centro de servicio de su área. Para obtener ayuda para ubicar un centro de servicio, llame sin costo a la línea de asistencia técnica o visite www.robinair.com.

**Visitez notre site Web à www.robinair.com ou appelez sans frais
le soutien technique au 800-822-5561
sur le territoire continental des États-Unis ou au Canada.**

Pour tout autre endroit, communiquez avec votre distributeur local. Afin de nous aider à mieux vous servir, soyez prêt à nous donner le numéro de modèle, le numéro de série et la date de l'achat de votre unité. Afin de valider votre garantie, remplissez la carte de garantie jointe à votre système et retournez-la dans les dix jours de la date d'achat.

RÉSEAU NATIONAL DES CENTRES DE SERVICE AUTORISÉS

Si votre unité a besoin d'être réparée ou à besoin de pièces de remplacement, communiquez avec le centre de service de votre région. Pour vous aider à localiser un centre de service, appelez sans frais la ligne de soutien technique ou visitez le www.robinair.com.

The Robinair 34788-H unit is designed to meet all applicable agency certifications, including Underwriter's Laboratories, Inc., SAE Standards, and CUL. Certain state and local jurisdictions dictate that using this equipment to sell refrigerant by weight may not be permitted. We recommend charging for any A/C service by the job performed. This weight scale provides a means of metering the amount of refrigerant needed for optimum A/C system performance as recommended by OEM manufacturers.

La unidad Robinair 34788-H está diseñada para cumplir con todas las certificaciones de agencia aplicables, incluyendo Underwriter's Laboratories, Inc., Estándares SAE y CUL. Ciertas jurisdicciones estatales y locales prescriben que el uso de este equipo para vender refrigerante por peso es posible que no sea permitido. Recomendamos que se cobre el trabajo realizado por dar servicio al aire acondicionado. Esta escala de peso proporciona un medio para medir la cantidad de refrigerante que se necesita para el rendimiento óptimo del sistema de aire acondicionado, tal como lo recomiendan los fabricantes OEM.

Le modèle 34788-H a été conçu pour répondre aux certifications applicables de la Underwriter's Laboratories, Inc., aux normes SAE et CUL. Certains endroits dictent l'utilisation de cet équipement et il peut arriver que la vente de fluide frigorigène en fonction du poids puisse être interdite. Nous vous recommandons de facturer les services de climatisation en fonction du travail effectué. Ce poids de tarification permet de calculer la quantité de fluide frigorigène nécessaire pour un rendement optimum de la climatisation, tel qu'il est recommandé par les fabricants de l'équipement d'origine.

Due to ongoing product improvements, we reserve the right to change design, specifications, and materials without notice.

Debido a las constantes mejoras del producto, nos reservamos el derecho de cambiar diseño, especificaciones y materiales sin aviso.

En raison des améliorations constantes apportées à nos produits, nous nous réservons le droit de changer de concept, de spécifications et de matériaux sans préavis.

ROBINAIR

655 EISENHOWER DRIVE
OWATONNA, MN 55060 USA

TECH SERVICES	800	822	5561
FAX	866	259	1241
CUSTOMER SERVICE	800	533	6127
FAX	800	322	2890

www.robinair.com