

ROBINAIR[®]



Operating Manual for
Model 34288
Recovery, Recycling, Recharging Unit

SAFETY DEFINITIONS: Follow all **WARNING**, **CAUTION**, and **NOTE** messages in this manual. These messages are defined as follows: **WARNING** means you may risk serious personal injury or death; **CAUTION** means you may risk personal injury, property damage, or unit damage; and **NOTES** and **OPERATING TIPS** provide clarity and helpful information. These safety messages cover situations ROBINAIR is aware of. ROBINAIR cannot know, evaluate, and advise you as to all possible hazards. You must verify that conditions and procedures do not jeopardize your personal safety.

DISCLAIMER: Information, illustrations, and specifications contained in this manual are based on the latest information available at the time of publication. The right is reserved to make changes at any time without obligation to notify any person or organization of such revisions or changes. Further, ROBINAIR shall not be liable for errors contained herein or for incidental or consequential damages (including lost profits) in connection with the furnishing, performance, or use of this material. If necessary, obtain additional health and safety information from the appropriate government agencies and the vehicle, refrigerant, and lubricant manufacturers.

WARNINGS



ALLOW ONLY QUALIFIED PERSONNEL TO OPERATE THE UNIT. Before operating the unit, read and follow the instructions and warnings in this manual. The operator must be familiar with air conditioning and refrigeration systems, refrigerants, and the dangers of pressurized components. If the operator cannot read this manual, operating instructions and safety precautions must be read and discussed in the operator's native language.



PRESSURIZED TANK CONTAINS LIQUID REFRIGERANT. Do not overfill the internal storage vessel, because overfilling may cause explosion and personal injury or death. Do not recover refrigerants into nonrefillable containers; use only federally authorized refillable containers (DOT spec. 4BW or 4BA).



HOSES MAY CONTAIN LIQUID REFRIGERANT UNDER PRESSURE. Contact with refrigerant may cause personal injury. Wear protective equipment, including safety goggles. Disconnect hoses using extreme caution.



AVOID BREATHING A/C REFRIGERANT AND LUBRICANT VAPOR OR MIST. Exposure may irritate eyes, nose, and throat. To remove refrigerant from the A/C system, use only equipment certified for the type of refrigerant being removed. Use the unit in locations with mechanical ventilation that provides at least four air changes per hour. If accidental system discharge occurs, ventilate the work area before resuming service.



DO NOT USE AN EXTENSION CORD. An extension cord may overheat and cause fire. If you must use an extension cord, use the shortest possible cord with a minimum size of 14 AWG.



TO REDUCE THE RISK OF FIRE, do not use the unit in the vicinity of spilled or open containers of gasoline or other flammable substances.



CAUTION—DO NOT PRESSURE TEST OR LEAK TEST EQUIPMENT AND / OR VEHICLE AIR CONDITIONING SYSTEMS WITH COMPRESSED AIR. Some mixtures of air and refrigerant have been shown to be combustible at elevated pressures. These mixtures, if ignited, may cause injury or property damage.



TO PREVENT CROSS-CONTAMINATION, USE THIS UNIT WITH R-134a REFRIGERANT ONLY. The unit is designed to recover, recycle, and recharge only R-134a refrigerant. Do not attempt to adapt the unit for another refrigerant. Do not mix refrigerant types through a system or in the same container; mixing of refrigerants will cause severe damage to the unit and the vehicle air conditioning system.



HIGH VOLTAGE ELECTRICITY INSIDE THE UNIT HAS A RISK OF ELECTRICAL SHOCK. Exposure may cause personal injury. Disconnect the power before servicing the unit.

Additional health and safety information may be obtained from the refrigerant and lubricant manufacturers.

OPERATING NOTE: At temperatures exceeding 120° F / 49° C, wait 10 minutes between recovery jobs.

Table of Contents

Introduction	2
Technical Specifications	2
Keypad Functions	3
Glossary	3
Menu Functions	4
Setup	5
Unpack the Accessory Kit	5
Power Up the Unit	5
Select a Language	5
Select Operating Units	5
Set Tank Fill Level	6
Add Oil to the Vacuum Pump	6
Fill the Internal Storage Vessel	7
Operating Instructions	8
Recover Refrigerant from a Vehicle	8
Evacuate the A/C System	9
Recharge the A/C System	10
Maintenance	12
General	12
Electrical Protection	12
Manually Fill the Internal Storage Vessel (ISV)	12
Replace the Filter-Drier	13
Check Remaining Filter Capacity	13
Change the Filter	13
Adjust Tank Fill Level	14
Check for Leaks	14
Change Vacuum Pump Oil	15
Replacement Parts	16
Scale Calibration	16
Tank Recertification	16
Spanish Manual	17
French Manual	35
Safety Precautions	Inside Front Cover
Warranty	Inside Back Cover

IMPORTANT: To comply with federal law governing A/C system service, you must complete and mail the MVAC Certification Form included in the accessory kit. Technicians using this equipment must be certified under EPA Section 609 (Environmental Protection Agency). For more information, read the MACS information included in the accessory kit, or visit the MACS website at www.macsw.org.

To validate the warranty provided by Robinair, complete the warranty card included in the accessory kit, and mail it within ten days from the purchase date of the unit.

Introduction

Robinair No. 34288 is used on R-134a vehicles and is designed to be compatible with existing service equipment and standard service procedures. Model No. 34288 is a UL-listed, single-pass system that meets SAE specifications for recycled refrigerant. Follow the SAE-J2211 recommended service procedure for the containment of R-134a.

The unit includes a 1.5 cfm (42 l/m) Robinair high vacuum pump for fast, thorough evacuation. The compressor pulls the A/C system to 0 psig, then works in series with the vacuum pump to achieve highly efficient recovery and immediate recharge. If the system is not opened for service, there is no need to pull additional vacuum. If the system is opened for service, use the unit's vacuum cycle to remove air and moisture from the A/C system. (We recommend a minimum 15-minute vacuum, or follow the vehicle manufacturer's specs.) *Note: R-134a systems require special oils. Refer to the A/C system manufacturer's service manual for oil specifications.*

Manifold Gauges:

connect to vehicle A/C system; show system's low-side and high-side pressure.

Panel Valves:

direct system's low-side and high-side pressure.

Tool Storage Area

(additional storage on back side for extra filter-driers and oil bottles).

Digital Display:

visual interface between operator and machine.

Main Power Switch:

supplies electrical power to unit.

Power Cord

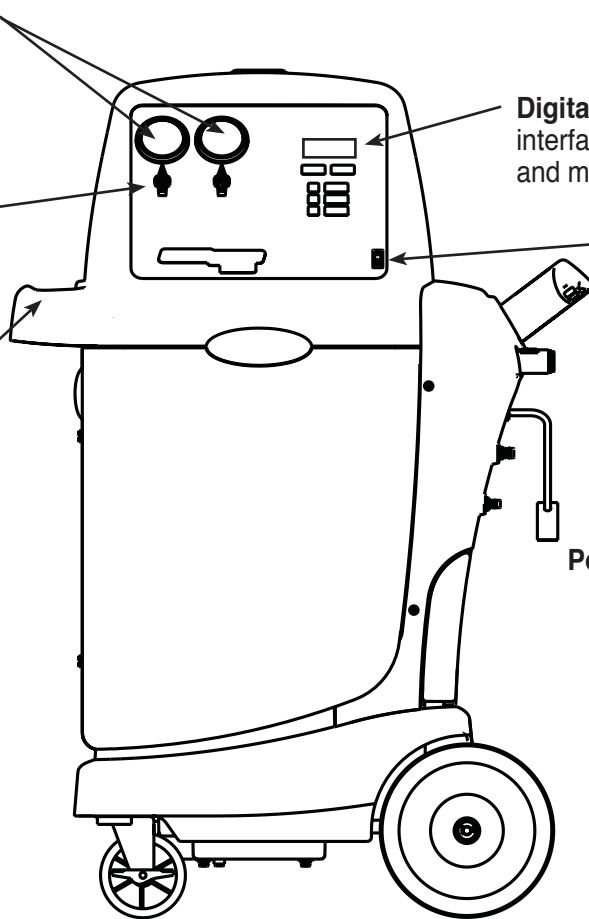







Technical Specifications

Voltage 115V, 60 Hz
Operating Range 50° to 120° F (11° to 49° C)
Filter-Drier 43 cu. in. spin-on type

Pump Free-Air Displacement ... 1.5 cfm (42 l/m)
Dimensions 49" H x 34" W x 23" D
 (124.5 cm x 86.4 cm x 58.4 cm)

Keypad Functions

	START / YES begins or resumes a function, or answers a query.
	STOP / NO terminates or pauses a function, or answers a query.
	MENU displays the selection menu.
	ARROWS are used for scrolling through menu items.
	RECOVER activates the recovery sequence.
	VACUUM activates the vacuum sequence.
	CHARGE charges the vehicle A/C system with a programmed amount of refrigerant.

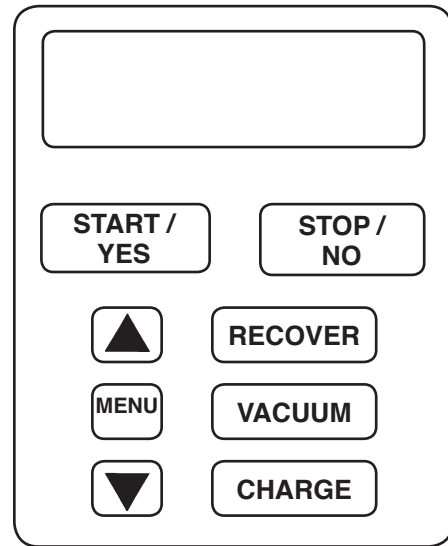

Keypad

Glossary

A/C System : The vehicle air conditioning system being serviced.

Internal Storage Vessel : The refillable refrigerant storage vessel designed specifically for this unit; 30 lb. (14 kg).

Source Tank : A disposable tank of new refrigerant used to refill the internal storage vessel; not included.

Unit : Model No. 34288.

Introduction

Menu Functions

1. Press the **MENU** button on the keypad.
2. Press the **UP** or **DOWN** arrow key to scroll through the menu choices shown on the second line of the display :

SELECT LANGUAGE
VERSION X.XX
SELECT UNITS
MAINTAIN VACUUM OIL
MAINTAIN FILTER
REFRIG MANAGEMENT
MANUAL REFILL
ADJUST TANK FILL LVL
CALIBRATION CHECK
SERVICE MENU
DISPLAY TANK INFO

3. Press **START / YES** to make a choice from the menu. Press **STOP / NO** to pause during any process, and **STOP / NO** a second time to exit a process.

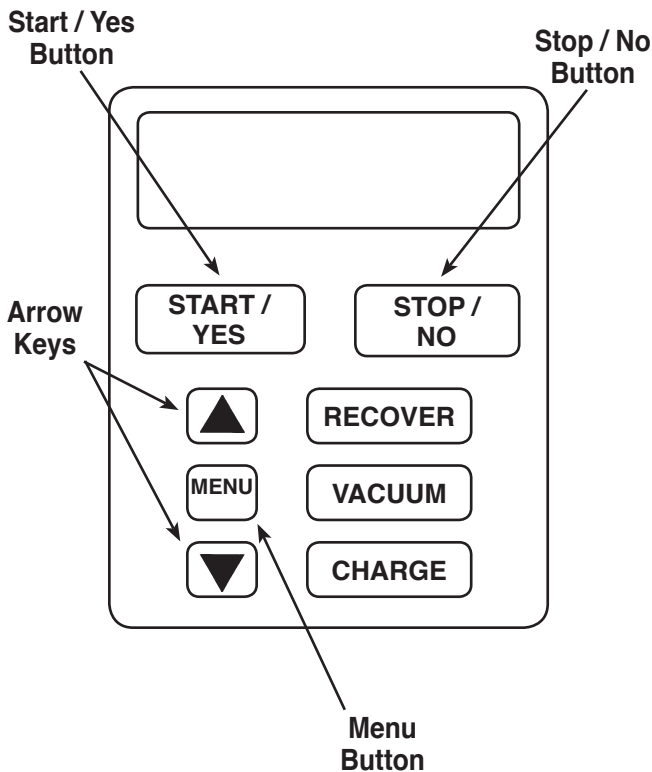

Select Language

Operator may choose to have prompts displayed in one of three languages: English, Spanish, or French.

Version X.XX

Displays the revision level of the software in the unit.

Select Units

The operator may choose to have test results displayed in Imperial (lb.), Imperial (lb. and oz.), or Metric (kg).

Maintain Vacuum Oil

For maximum vacuum pump performance, change vacuum pump oil after every 10 hours of operation. This menu item displays how long the vacuum pump has operated since the last oil change, and allows the user to reset the value once an oil change is complete. Refer to the instructions outlined in the Maintenance section under *Change Vacuum Pump Oil*.

Maintain Filter

The filter-drier removes acid, particulates, and moisture from the refrigerant. To meet SAE J-2788 requirements, it is mandatory to replace the filter-drier after 150 lbs. (68 kg) of refrigerant has been filtered. This menu item shows how much refrigerant has been filtered since the last filter change, and allows the user to reset the value once a filter change is complete. A code, which appears on the filter, must be entered into the unit to ensure compliance with SAE J-2788. Refer to the instructions outlined in the Maintenance section under *Replace the Filter-Drier*.

Refrig Management

Displays the amount of refrigerant recovered, charged, and replenished (for the life of the unit), and filtered (since the last filter change).

Manual Refill

Use to transfer refrigerant from the source tank to the internal storage vessel (ISV). Refer to instructions outlined in the Maintenance section under *Manually Fill the ISV*.

Adjust Tank Fill Lvl

During the tank refill process, the unit stops refilling when it reaches the pre-set amount of refrigerant in the internal storage vessel (default is 15 lbs.). This value may be adjusted up or down to suit the user's needs. Refer to instructions outlined in the Maintenance section under *Adjust Tank Fill Level*.

Calibration Check

Use to verify internal scale calibration. Refer to instructions in Maintenance section under *Scale Calibration Check*.

Service Menu

For Robinair service center use only.

Display Tank Info

Displays internal storage vessel (ISV) pressure and temperature. Use to check the ISV for excessive pressure.

Unpack the Accessory Kit

Unpack the accessory kit from the bag, and remove the plastic packaging. The kit consists of

- Low-side tank adapter.
- Calibration weight.
- Vacuum pump oil, oil filler cap, and tube.
- Plastic pouch containing a warranty card (to be completed and mailed), applicable MSDS sheets, a service center listing, and an envelope of Mobile Air Conditioning Society (MACS) information.

Important: You must complete and mail the MVAC Certification Form, and your technicians must be certified with the Environmental Protection Agency (EPA) to operate this equipment.

Power Up the Unit

1. Unwind the power cord from the handle, and plug it into a correct voltage outlet. See Figure 1.
2. Turn on the main power switch. The first time the unit is powered up, it displays the initial setup mode.

Select a Language – English Seleccionar Idioma – Espanol Selection Langue – Francais

The operator may choose to have prompts displayed in one of three languages: English, Spanish, or French.

1. Use the **UP** or **DOWN** arrow key to toggle through the choices for English, Spanish, or French.
2. Press **START / YES** to select the displayed language.

Select Operating Units

The operator may choose to have test results displayed in Imperial (lb., or lb. and oz.) or Metric (kg) units.

1. Use the **UP** or **DOWN** arrow key to toggle through choices for IMPERIAL UNITS or METRIC UNITS.
2. Press **START / YES** to select the displayed operating unit choice.

IMPORTANT : R-134a systems have special fittings (per SAE specifications) to avoid cross-contamination with R-12 systems. DO NOT adapt your unit for a different refrigerant – system failure will result.

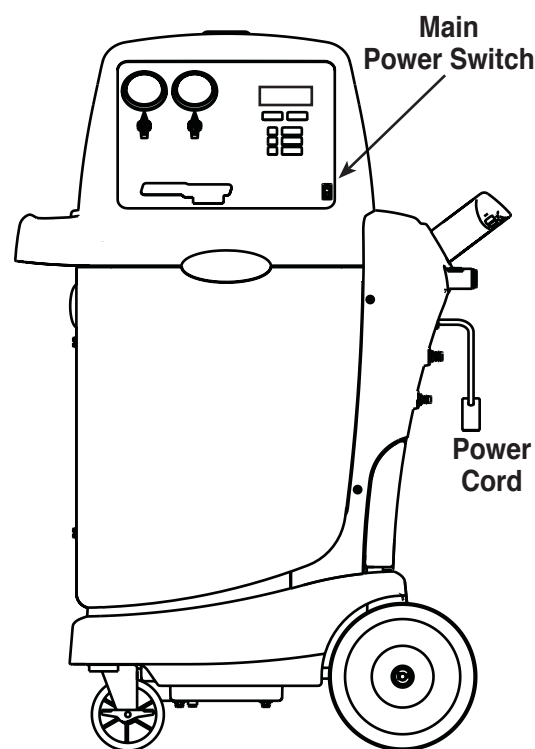

Figure 1

Setup

Set Tank Fill Level

The operator may either accept the unit's pre-set default weight of 15 lbs. (6.8 kg) of refrigerant stored in the internal storage vessel (ISV), or change the amount to accommodate the application.

The unit displays

LEVEL: 15.00 LBS.
ENTER TANK FILL LVL
LIMIT: 4 TO 17 LBS.
PRESS START / YES TO SAVE

1. Press **START / YES** to accept the default amount, or use the arrow keys to enter a desired amount and press **START / YES**.

Add Oil to the Vacuum Pump

IMPORTANT: The vacuum pump is shipped without oil in the reservoir. Failure to add oil to the vacuum pump will damage the pump.

The unit displays

ADD 5 OZ OF NEW OIL
TO VACUUM PUMP
START TO CONTINUE

1. Remove the brass plug from the vacuum pump oil fill port. See Figure 2.
2. Attach the flexible tube/cap to the oil bottle; pour **only** five (5) ounces of vacuum pump oil into the fill port.
Note: You will top off the oil in the next step as the vacuum pump is running.
3. Press and release the **START / YES** key. While the vacuum pump is running, slowly add oil until the level rises to the center of the reservoir's sight glass.
4. Press the **STOP / NO** key to stop the vacuum pump, and install the brass plug in the fill port.
5. Press **START / YES** to continue.

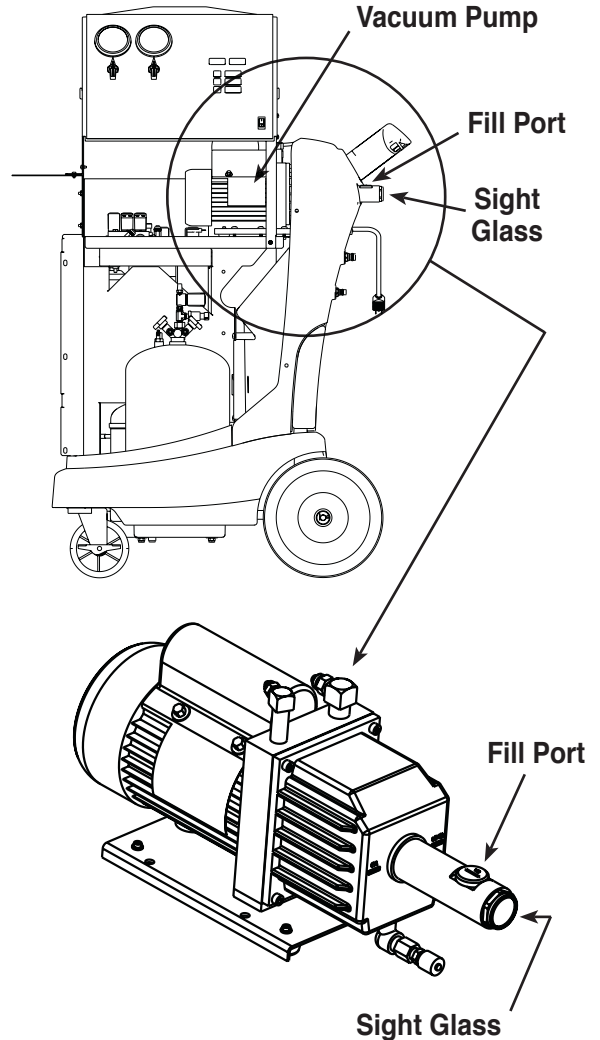

Figure 2

⚠ CAUTION: The unit is programmed to run the setup procedure as outlined here. To prevent personal injury, do **NOT** operate the unit at any other time without the brass plug installed, because the vacuum pump is pressurized during normal operation.

Fill the Internal Storage Vessel (ISV)

1. Press **START / YES**, and the unit automatically runs a 5-minute vacuum to clear all internal air.

Note: The “burping” noise heard during this process indicates air is being purged from the system—this is normal.

2. After the vacuum pump shuts off, attach the low-side tank adapter to the liquid valve on the tank. Attach the low-side service hose to this adapter. See Figure 3.
3. Open the source tank valve and the low-side panel valve. See Figure 4.
4. Install the source tank, and secure it to the unit (using the tank strap) in such a way that liquid refrigerant is supplied to the connection.
5. Press **START / YES** to begin filling the internal storage vessel. Add at least 8 lbs. (3.6 kg) of refrigerant to ensure enough refrigerant is available for charging.

This process takes 15–20 minutes. The unit stops when a sufficient amount of refrigerant has been transferred to the internal tank, or when the source tank is empty.

Press **STOP / NO** to pause. Press **STOP / NO** again to exit, or **START / YES** to resume.

6. When the fill process is complete, press **STOP / NO** to exit. Close the source tank valve. Disconnect the low-side service hose.

The unit is ready for operation.

Note: There is no need to calibrate the scale; it is calibrated at the factory.

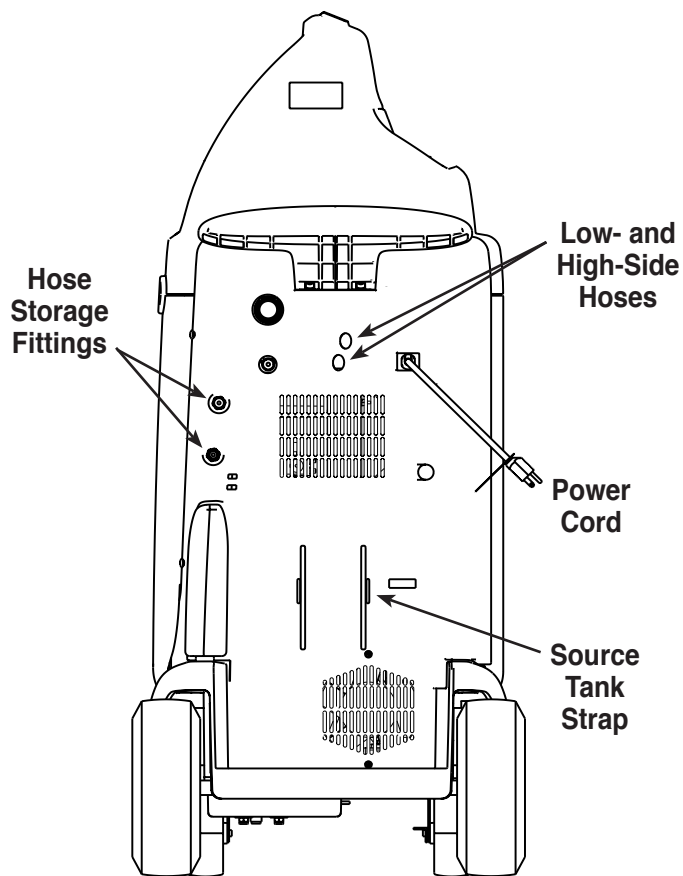

Figure 3

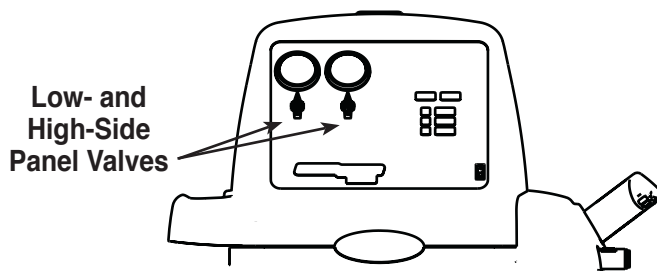

Figure 4

Operating Instructions

Recover Refrigerant from a Vehicle

1. Empty the oil drain bottle located on the right-hand side of the unit, if necessary, or make note of the current oil level. See Figure 5.
2. Connect the high- and low-side hoses to the vehicle A/C system.
3. Open the coupler valves on the hoses.
4. Open the high- and low-side panel valves on the control panel.
5. Press the **RECOVER** button.

Note: The clicking noise heard during the recovery process indicates the solenoid is opening and closing — this is normal.

6. When the system has recovered to 0 psi, the vacuum pump starts and runs until recovery is complete. The unit then goes into an automatic oil drain—this may require 90 seconds to complete.
7. After the oil drain is complete, the display shows

RECOVER COMPLETE
RECOVERED XX.XX LBS. (X.XX KG)
CHECK OIL BOTTLE

Note: The displayed recovered weight can vary, depending on ambient conditions, and should not be used as an indicator of scale accuracy.

8. Check the oil drain bottle, and note the amount of oil that was removed from the A/C system. This is the amount of new oil that must be charged into the A/C system after evacuation is complete.
- Use only **new** oil to replace the oil removed during the recycling process.
 - Dispose of used oil according to local, state, and federal regulations.

Recovery is complete. You are now ready to either advance to the charge process, or to make repairs to the A/C system followed by the evacuation process.

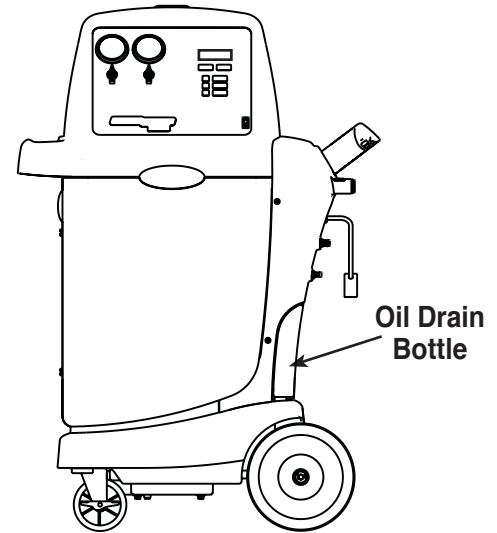

Figure 5

Operating Tips

After the **RECOVER** function is selected :

- If system pressure is below 10 psi, the display reads

LOW RECOVER PRESSURE
CHECK CONNECTIONS

*until pressure increases, or the **START / YES** button is pressed. Verify the high- and low-side hoses are connected and coupler valves are open. Press **STOP / NO** to exit.*

- If 100 lbs. (45 kg) or more of refrigerant has been recovered since the last filter-drier change, the display reads

FILTER WEIGHT XXX LB (XX KG)

To meet SAE J-2788 requirements, it is mandatory to replace the filter-drier after 150 lbs. (68 kg) of refrigerant has been filtered. The unit gives a warning to replace the filter when filter weight reaches 100 lbs.; when filter weight reaches 150 lbs., **the unit locks out and ceases to operate.** Refer to instructions outlined in the Maintenance section under Replace the Filter-Drier.

Operating Instructions

Evacuate the A/C System

1. Ensure service hoses are connected, and coupler valves are OPEN.
2. Press **VACUUM**.
3. Press **START / YES** to accept the default evacuation time of 10 minutes, or enter the desired vacuum time using the number keys, and press **START / YES**.

IMPORTANT: The unit pulls a vacuum on the vehicle A/C system to remove air and boil off moisture that may be present in the system. Evacuate the system for at least 10 minutes, or follow the A/C system manufacturer's specifications, to ensure adequate moisture and contaminant removal.

4. The unit evacuates the A/C system and stops when the specified amount of time has elapsed.

Press **STOP / NO** to pause the process. Press **START / YES** to resume, or **STOP / NO** again to exit.

You are now ready to replenish the A/C system with new oil, if necessary, or to recharge the system with refrigerant.

Operating Tips

- *If the vacuum pump has run for 10 or more hours without an oil change, the unit displays*

VACUUM OIL TIME XX:XX
CHANGE OIL NOW?

Refer to instructions outlined in the Maintenance section under Change Vacuum Pump Oil.

- *Before the unit begins evacuating the A/C system, it checks for any pressure in the system that might damage the vacuum pump. If pressure is detected, the unit displays*

PRESSURE EXISTS
PRESS ANY KEY TO EXIT

Press any key to exit, and recover refrigerant before proceeding.

Operating Instructions

Recharge the A/C System

1. Press **CHARGE**. Open the appropriate panel valve(s), depending on where the system should be charged – high-side, low-side, or both.
2. Press **CHARGE** again to change the units of measure. Accept the default weight by pressing **START / YES**, or use the arrow keys to scroll to the correct amount, and press **START / YES**.

3. The display reads

CHARGE IN PROGRESS / DO NOT DISTURB
X.XX LBS. (X.XX KG)

Moving or bumping the unit at this point may result in an incorrect reading.

Note:

- *During a charge cycle, if the unit fails to transfer refrigerant due to low tank pressure, the charge process is automatically interrupted and the unit operates in a mode to build tank pressure. Once tank pressure is sufficient, the unit automatically completes the charge.*
- *When the charge cycle gets close to the weight entered in Step 2, the unit slows down. It'll charge, settle, charge again, settle, etc.*

4. When the charge is complete, the display reads

CHARGED XXX LBS (KG)
PRESS START TO EQUALIZE HOSES

The user must equalize pressure in the service hoses to ensure all liquid refrigerant trapped in the hoses is transferred to the vehicle A/C system for an accurate charge. Press **START / YES** to equalize hoses.

5. Close the high-side coupler valve. The display reads

DISCONNECT HS HOSE
OPEN PANEL VALVES
AND START A/C MAX
START TO CONTINUE

The high-side hose must be removed from the vehicle, and **the low-side hose must stay connected to the vehicle** with the low-side coupler open.

6. Open both panel valves.

Operating Tips

- *After selecting the **CHARGE** function and entering a desired weight, if the weight entered will leave less than 2 lbs. (.91 kg) of refrigerant in the internal tank after charge, the charge function will not start. The display reads*

INSUFFICIENT REFRIG.
PRESS ANY KEY TO EXIT

Refer to the Maintenance section of this manual for instructions to Manually Refill the Internal Storage Vessel (ISV).

Recharge the A/C System contd.

7. Place the vehicle gear selector in park or neutral, with the emergency brake ON.
8. Start the vehicle. The A/C system should be set at maximum.
9. Press **START / YES**. The display reads

EQUALIZING HOSES
REMOVE LS HOSE WHEN
HS + LS ARE < 40 PSI
PLEASE WAIT

This allows the vehicle's compressor to pull refrigerant into the A/C system. When both gauges read below 40 psi, close both panel valves and the low-side coupler valve. The display reads

DISCONNECT LOW SIDE HOSE
START TO CONTINUE

10. Close the low-side coupler valve. Remove the service hoses from the A/C system.

IMPORTANT: If the low-side or high-side coupler valves are left open, the system will pull the refrigerant back out of the vehicle.

11. Shut OFF the vehicle.
12. Press **START / YES** to begin clearing the hoses.

CLEARING HOSES
PLEASE WAIT

When the hoses are cleared, the display reads

CHARGE COMPLETE
CHARGED XX.XX LBS
ANY KEY EXITS

The A/C system is now ready for use.

 **WARNING:** To prevent personal injury,

- **Verify the vehicle is in park or neutral with the emergency brake ON before starting the engine.**
 - **Never run a vehicle without adequate ventilation in the work area.**
-
-

Maintenance

General Maintenance

1. On a regular basis, wipe off the unit using a clean cloth to remove grease and dirt.
2. Periodically check internal components for leaks; over time, fittings can loosen as the unit is moved. Open the door panel, and trace lines using a leak detector. Check connections on the back of the unit. Tighten any loose fittings or connections you may find.

Electrical Protection

The unit is equipped with a 15 amp circuit breaker on the back panel. See Figure 6. If the breaker trips, its button will pop out. A tripped circuit breaker will cause the unit to lose all power.

Press the circuit breaker button to reset.

Manually Fill the Internal Storage Vessel (ISV)

This menu item is used to transfer refrigerant from a source tank to the internal storage vessel.

1. Press **Menu**, and use arrow keys to select MANUAL REFILL. Press **START / YES**. The unit displays

CONNECT SOURCE TANK
TO LS SERVICE HOSE
OPEN LS PANEL VALVE
START TO BEGIN

2. Connect the low-side tank adapter to the liquid valve on the tank. Connect the low-side service hose to this tank adapter. Open the low-side panel valve.
3. Install the source tank, and secure it to the unit with the source tank strap in such a way that liquid refrigerant is supplied to the connection.
4. Press **START / YES** to begin. The display shows

TANK FILL IN PROGRESS
TRANSFER XX LBS

5. The unit automatically stops when the preset tank fill level is reached, or press **STOP / NO** to exit.
6. Close the source tank valve. Disconnect the low-side service hose.

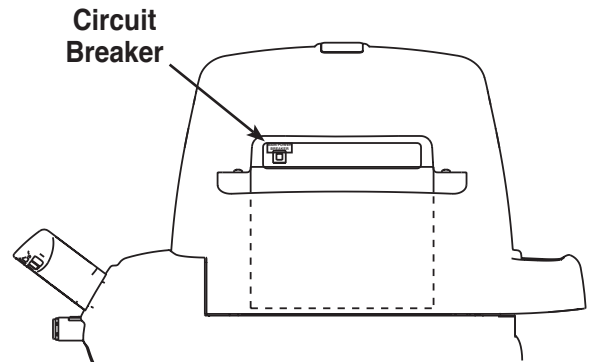

Figure 6
Back View

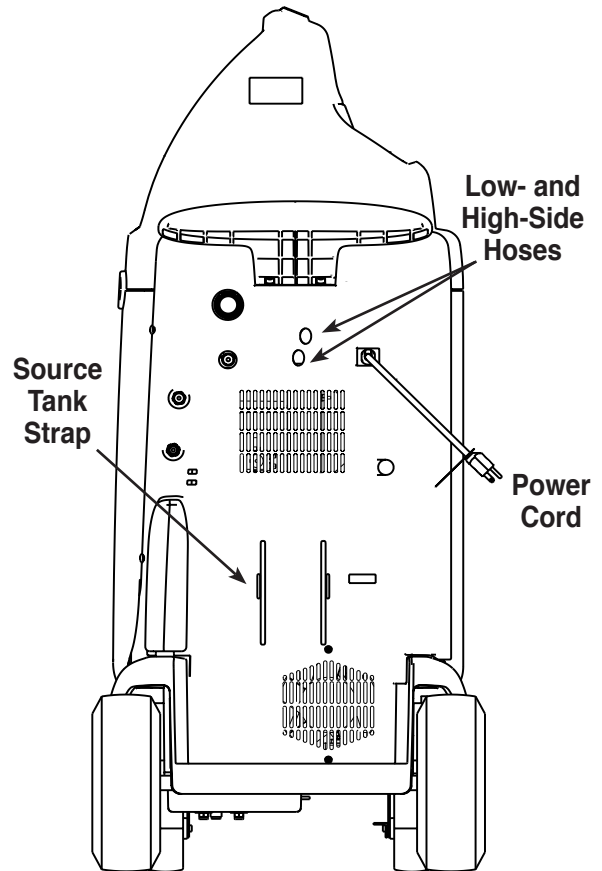

Figure 7
Side View

Replace the Filter-Drier

The filter-drier is designed to trap acid and particulates, and to remove water from refrigerant. To meet the SAE J-2788 mandate for adequate moisture and contaminant removal, the filter-drier must be replaced after 150 lbs. (68 kg) of refrigerant has been filtered.

Therefore, you no longer have a choice—the filter-drier must be replaced. The unit gives a warning when 100 lbs. of the filter capacity has been used; **the unit locks down when the 150 lb. filter capacity has been reached and will no longer function.** For this reason, always have a spare Robinair No. 34724 filter-drier on hand.

Check Remaining Filter Capacity

1. Press **MENU**.
2. Use the arrow keys to scroll through the menu to **MAINTAIN FILTER**, and press **START / YES**.
The unit displays

XXX LBS FILTERED
RECOVER LOCKOUT IN XXX LBS
REPLACE FILTER NOW?
PRESS STOP TO EXIT

3. Press **STOP / NO** to exit.

Change the Filter

1. Press **MENU**.
2. Use the arrow keys to scroll through the menu to **MAINTAIN FILTER**, and press **START / YES**.
The unit displays

XXX LBS FILTERED
RECOVER LOCKOUT IN XXX LBS
REPLACE FILTER NOW?
PRESS STOP TO EXIT

3. Press **START / YES** to proceed.
4. If there is pressure in the filter, the unit begins a clearing process. When complete, the display reads **ENTER 10 DIGIT SERIAL NUMBER**. Use the arrow keys to enter the serial number that appears on the new filter-drier, and press **START / YES**.

IMPORTANT: Use only authentic Robinair No. 34724 filter-driers in this machine. All performance tests and claims are based on using this specific filter-drier.

And only the Robinair No. 34724 filter-drier includes the code necessary to make the unit operable again.

Operating Tips

Enter the Serial No. for a New Filter-Drier

Use an arrow key to change the selected digit to the corresponding number or letter in the serial number. When the correct letter or number is displayed, press **START / YES** to select it and move to the next digit. Repeat this process until the entire serial number has been entered, and press **START / YES**.

Replace the Filter-Drier contd.

5. The display reads **PLEASE REPLACE FILTER**.
Open the rear door of the unit and unscrew the old filter. See Figure 8.
6. Look at the new filter—verify both o-rings are lubricated and correctly located in the grooves. See Figure 9. Thread the new filter into place. Press **START / YES**.

Note: If the display shows SERIAL NUMBER ERROR, the serial number is invalid or the filter-drier has already been used in this unit.

7. Close the door. Press **STOP / NO** to exit. The filter-drier replacement is now complete.

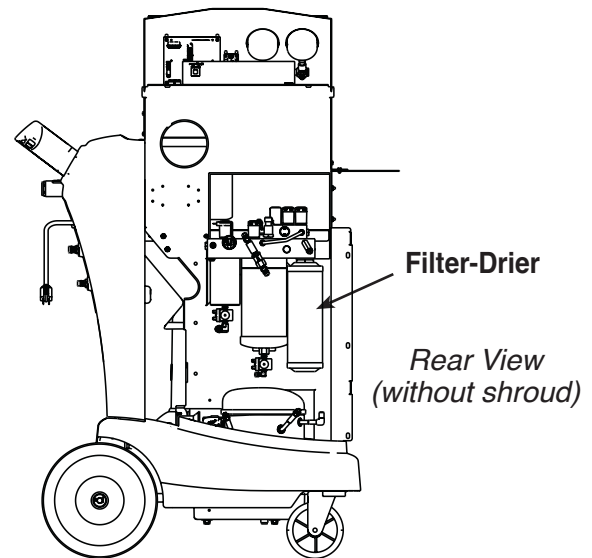

Figure 8

Adjust Tank Fill Level

When connected to a refrigerant source, the unit maintains a default value of 15 lbs. of refrigerant in the internal storage vessel. This value may be adjusted up or down to suit the application.

1. Press **MENU**.
2. Use the arrow keys to scroll through the menu to **ADJUST TANK FILL LVL**, and press **START / YES**. The unit displays

LEVEL: 15.00 LBS.
ENTER TANK FILL LVL
LIMIT: 4 TO 17 LBS.
PRESS START / YES TO SAVE

3. Use the arrow keys to enter a value between 4 lbs. and 17 lbs., and press **START / YES**.

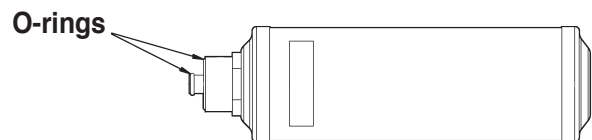

Figure 9

Check for Leaks

Check the unit for leaks every three months, or as specified by law in your jurisdiction.

1. Turn off **MAIN POWER**, and disconnect the power cord from the outlet.
2. Open the rear door; remove top cover and front panel.
3. Use a leak detector to probe all connections for refrigerant leaks. Tighten fittings if a leak is indicated.
4. Reassemble the body panels, and close the rear door.

Inspect the unit periodically for leaks. The manufacturer does not reimburse for lost refrigerant.

Change Vacuum Pump Oil

For maximum vacuum pump performance, change the vacuum pump oil after every 10 hours of operation. (The unit will display a prompt after 10 hours of operation.)

1. Press **MENU**. Use the arrow keys to select **MAINTAIN VACUUM OIL**, and press **START / YES**. The display shows how long the vacuum pump has operated since the last oil change:

PUMP OIL TIME X:XX
TIME REMAINING X:XX
CHANGE OIL?

2. Press **START / YES**. The display shows **VACUUM OIL CHANGE TIME 2:00**, and counts down to zero. Allow the vacuum pump to run until it automatically stops. The display then shows **DRAIN OLD OIL AND ADD 5 OZ NEW OIL**.
3. Refer to Figure 10, and remove the brass plug from the vacuum pump's oil fill port. (The pump drains faster when vented.)
4. Remove the oil drain fitting cap, and drain the oil into a suitable container for disposal. Replace the cap.
5. Attach the flexible tube and cap to the oil bottle; pour five (5) ounces of vacuum pump oil into the fill port.
6. Press **START / YES**. The display shows **FILL PUMP TO CENTER OF SIGHT GLASS**, and the vacuum pump starts. While the vacuum pump is running, slowly add oil until the level rises to the center of the reservoir's sight glass.
7. Press **STOP / NO**. The counter resets to zero after a vacuum pump oil change has been completed.
8. Replace the brass plug on the fill port. Press **STOP / NO** to exit to the Main Menu.

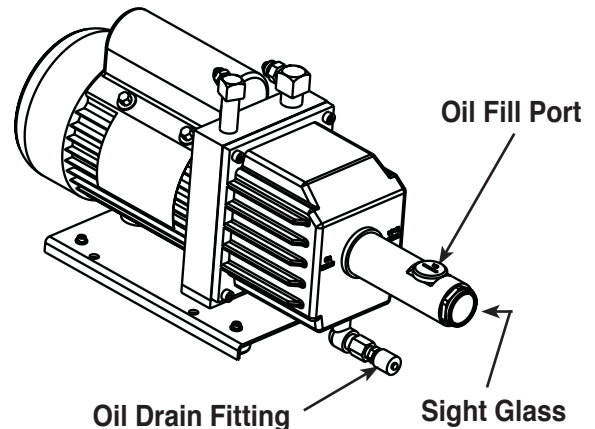

Figure 10

Review the laws in your jurisdiction to determine the correct disposal procedure for pump oil. It is the responsibility of the user to determine if a material is a hazardous waste at the time of disposal. Ensure you are in compliance with all applicable laws and regulations.

⚠ CAUTION: To prevent personal injury, do NOT operate the unit at any time without the brass plug installed, because the vacuum pump is pressurized during normal operation.

Maintenance

Scale Calibration

The calibration check is used to ensure the unit's internal scale is always calibrated. During this test, use only the calibration weight that is provided with the unit.

1. Press **Menu**.
2. Use the arrow keys to scroll to CALIBRATION CHECK.
3. Refer to Figure 11, and verify the magnet on the bottom of the unit is clean. Press **START / YES**.
4. The display reads
ATTACH THE WEIGHT TO THE BOTTOM OF THE MACHINE
PRESS START TO CONTINUE
5. Attach the weight provided to the magnet on the bottom of the unit. Press **START / YES**.

- If the display shows CALIBRATION APPROVED, the scale is in calibration. Press any key to exit.
- If the display shows CALIBRATION REJECT, the scale is out of calibration. Call your local service center for assistance.
- If the display shows CALIBRATION ERROR 1, verify the calibration weight is correctly attached to the magnet, and verify the magnet is clean with nothing attached to it. If that does not correct the problem, call your local service center for assistance.

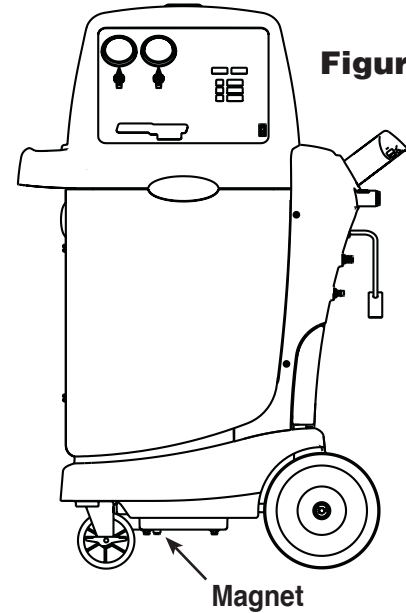

Figure 11

Tank Recertification

The internal storage vessel (ISV) in this unit is a DOT-approved tank that carries a date code. ISVs must be recertified every five years.

To determine the date code of the ISV in your Robinair unit, remove the front panel of the unit. It should be possible to read the date code stamped on the ISV.

If the date code reads beyond the five-year limit, contact a Robinair service center for assistance.

Replacement Parts

Component	Repl. Part No.
Filter-Drier	34724
Service Coupler Set (high- and low-side couplers)	18192
Service Hose Set (high- and low-side hoses)	34722
Vacuum Pump Oil (case of 12 quarts)	13203
Vacuum Pump Oil (case of 4 gallons)	13204
Maintenance Kit	13172
Vinyl Dust Cover (optional)	17492
Tank Adapter	16301

Robinair Limited Warranty Statement

Rev. November 1, 2005

This product is warranted to be free from defects in workmanship, materials, and components for a period of one year from date of purchase. All parts and labor required to repair defective products covered under the warranty will be at no charge. The following restrictions apply:

1. The limited warranty applies to the original purchaser only.
2. The warranty applies to the product in normal usage situations only, as described in the Operating Manual. The product must be serviced and maintained as specified.
3. If the product fails, it will be repaired or replaced at the option of the manufacturer.
4. Transportation charges for warranty service will be reimbursed by the factory upon verification of the warranty claim and submission of a freight bill for normal ground service. Approval from the manufacturer must be obtained prior to shipping to an authorized service center.
5. Warranty service claims are subject to authorized inspection for product defect(s).
6. The manufacturer shall not be responsible for any additional costs associated with a product failure including, but not limited to, loss of work time, loss of refrigerant, cross-contamination of refrigerant, and unauthorized shipping and/or labor charges.
7. All warranty service claims must be made within the specified warranty period. Proof-of-purchase date must be supplied to the manufacturer.
8. Use of recovery/recycling equipment with unauthorized refrigerants or sealants will void warranty.
 - Authorized refrigerants are listed on the equipment or are available through the Technical Service Department.
 - The manufacturer prohibits the use of the recovery/recycling equipment on air conditioning (A/C) systems containing leak sealants, either of a seal-swelling or aerobic nature.

This Limited Warranty does NOT apply if:

- The product, or product part, is broken by accident.
- The product is misused, tampered with, or modified.
- The product is used for recovering or recycling any substance other than the specified refrigerant type. This includes, but is not limited to, materials and chemicals used to seal leaks in A/C systems.

Declaración de garantía limitada Robinair

Revisión del 1 de noviembre de 2005

Se garantiza que este producto no posee defectos de mano de obra, materiales y componentes por el período de un año a partir de la fecha de compra. Todas las partes y mano de obra requerida para reparar los productos con defecto cubiertos bajo la garantía no tendrán costo. Aplican las siguientes restricciones:

1. La garantía limitada aplica al comprador original únicamente.
2. La garantía aplica al producto en situaciones de uso normal únicamente, como lo indica el Manual de funcionamiento. Al producto se le debe dar servicio y mantenimiento como se especifica.
3. Si falla el producto, se debe reparar o reemplazar a discreción del fabricante.
4. Los cargos de transporte de servicio de garantía serán reembolsados por la fábrica al verificar el reclamo de garantía y presentar una boleta de flete por servicio terrestre regular. Se debe obtener la aprobación del fabricante antes de hacer el envío a un centro de servicio autorizado.
5. Los reclamos de servicio de garantía están sujetos a inspección de defectos del producto.
6. El fabricante no será responsable de los costos adicionales relacionados con fallas en el producto, que incluyen pero no se limitan a, tiempo improductivo, pérdida de refrigerante, contaminación de refrigerante y envío no autorizado o cargos por mano de obra.
7. Todo reclamo de servicio de garantía se debe hacer dentro del período de garantía establecido. Se debe proporcionar la fecha de la prueba de compra al fabricante.
8. El uso de equipo de recuperación/reciclaje con refrigerantes o selladores no autorizados anula la garantía.
 - Los refrigerantes autorizados se indican en el equipo o están disponibles a través del Departamento de servicio técnico.
 - El fabricante prohíbe el uso de equipo de recuperación/reciclaje en sistemas de aire acondicionado (A/C) con fugas de sellador, ya sea porque un sello se infla o es de naturaleza aeróbica.

Esta garantía limitada NO aplica si:

- El producto, o parte de éste, se rompe accidentalmente.
- El producto se usa incorrectamente, se adultera o modifica.
- El producto se usa para recuperar o reciclar cualquier sustancia que sea diferente al tipo de refrigerante establecido. Esto incluye, pero no se limita a materiales y productos químicos utilizados para sellar fugas en sistemas de A/C.

Énoncé de la garantie limitée de Robinair

Révisée le 1er novembre 2005

Ce produit est couvert contre les défauts de matériau, de fabrication et de composant pendant un an à compter de la date d'achat. Toutes les pièces et la main-d'œuvre nécessaires aux réparations sous garantie sont sans frais. Toutefois, les restrictions suivantes s'appliquent :

1. La garantie limitée s'applique uniquement à l'acheteur initial.
2. La garantie s'applique uniquement au produit utilisé dans des conditions de fonctionnement normales conformément au manuel d'utilisation. Il doit être réparé et entretenu conformément aux spécifications.
3. Si le produit subit une défaillance, il sera réparé ou remplacé à la discrétion du fabricant.
4. Les frais de transport pour les réparations sous garantie sont remboursés par l'usine après l'évaluation de la réclamation au titre de la garantie et après la soumission d'une facture de transport terrestre standard. L'approbation du fabricant est requise avant l'expédition du produit à un atelier de réparation autorisé.
5. Les réclamations au titre de la garantie sont sujettes à l'inspection du produit défectueux par un personnel autorisé.
6. Le fabricant ne peut être tenu responsable pour tout coût supplémentaire lié à la défaillance du produit incluant, sans toutefois s'y limiter, les interruptions de fonctionnement, la perte de liquide frigorigène, la contamination des liquides frigorigènes et l'expédition et/ou les frais de main-d'œuvre soumis par des ateliers non autorisés.
7. Toute réclamation pour des réparations au titre de la garantie doit être soumise durant la période de garantie. Une preuve d'achat doit être fournie au fabricant.
8. L'utilisation d'un appareil de récupération et de recyclage avec du liquide frigorigène ou des scellants non spécifiés annule la garantie.
 - Les liquides frigorigènes autorisés sont indiqués sur l'appareil, ou ils peuvent être obtenus auprès du Service technique.
 - Le fabricant interdit l'utilisation d'un appareil de récupération et de recyclage dans les systèmes de climatisation contenant des colmatants pour fuites, que ce soient des scellants à dilatation ou aérobiques.

Cette garantie limitée NE s'applique PAS si le produit :

- ou une partie du produit a été endommagé par un accident.
- a été utilisé de façon inadéquate, ou qu'il a été altéré ou modifié.
- est utilisé pour la récupération et le recyclage de substances autres que le type de liquide frigorigène spécifié. Ces substances comprennent, sans toutefois s'y limiter, les matériaux et les produits chimiques utilisés pour colmater les fuites des systèmes de climatisation.

**Visit our web site at www.robinair.com or call our toll-free
Technical Support Line at 800-822-5561
in the continental U.S. or Canada.**

In all other locations, contact your local distributor. To help us serve you better, please be prepared to provide the model number, serial number, and date of purchase of your unit. To validate your warranty, complete the warranty card attached to the unit, and return it within ten days from date of purchase.

NATIONWIDE NETWORK OF AUTHORIZED SERVICE CENTERS

If your unit needs repair or replacement parts, contact the service center in your area. For help in locating a service center, call the toll-free technical support line or visit www.robinair.com.

**Visite nuestro sitio web en www.robinair.com o llame sin costo a
la línea de Asistencia técnica al 800-822-5561
en EE.UU. continental o Canadá.**

En todas las demás ubicaciones, comuníquese con su distribuidor local. Para ayudarnos a servirle mejor, tenga a mano el número de modelo, número de serie y fecha de compra de su unidad. Para validar la garantía, complete la tarjeta de garantía anexa a su unidad y devuélvala dentro de los diez días siguientes a la fecha de compra.

RED NACIONAL DE CENTROS DE SERVICIO AUTORIZADOS

Si su unidad necesita reparaciones o partes de reemplazo, comuníquese con el centro de servicio de su área. Para obtener ayuda para ubicar un centro de servicio, llame sin costo a la línea de asistencia técnica o visite www.robinair.com.

**Visitez notre site Web à www.robinair.com ou appelez sans frais
le soutien technique au 800-822-5561
sur le territoire continental des États-Unis ou au Canada.**

Pour tout autre endroit, communiquez avec votre distributeur local. Afin de nous aider à mieux vous servir, soyez prêt à nous donner le numéro de modèle, le numéro de série et la date de l'achat de votre unité. Afin de valider votre garantie, remplissez la carte de garantie jointe à votre système et retournez-la dans les dix jours de la date d'achat.

RÉSEAU NATIONAL DES CENTRES DE SERVICE AUTORISÉS

Si votre unité a besoin d'être réparée ou à besoin de pièces de remplacement, communiquez avec le centre de service de votre région. Pour vous aider à localiser un centre de service, appelez sans frais la ligne de soutien technique ou visitez le www.robinair.com.

The Robinair 34288 unit is designed to meet all applicable agency certifications, including Underwriter's Laboratories, Inc., SAE Standards, and CUL. Certain state and local jurisdictions dictate that using this equipment to sell refrigerant by weight may not be permitted. We recommend charging for any A/C service by the job performed. This weight scale provides a means of metering the amount of refrigerant needed for optimum A/C system performance as recommended by OEM manufacturers

La unidad Robinair 34288 está diseñada para cumplir con todas las certificaciones de agencia aplicables, incluyendo Underwriter's Laboratories, Inc., Estándares SAE y CUL. Ciertas jurisdicciones estatales y locales prescriben que el uso de este equipo para vender refrigerante por peso es posible que no sea permitido. Recomendamos que se cobre el trabajo realizado por dar servicio al aire acondicionado. Esta escala de peso proporciona un medio para medir la cantidad de refrigerante que se necesita para el rendimiento óptimo del sistema de aire acondicionado, tal como lo recomiendan los fabricantes OEM.

Le modèle 34288 a été conçu pour répondre aux certifications applicables de la Underwriter's Laboratories, Inc., aux normes SAE et CUL. Certains endroits dictent l'utilisation de cet équipement et il peut arriver que la vente de fluide frigorigène en fonction du poids puisse être interdite. Nous vous recommandons de facturer les services de climatisation en fonction du travail effectué. Ce poids de tarification permet de calculer la quantité de fluide frigorigène nécessaire pour un rendement optimum de la climatisation, tel qu'il est recommandé par les fabricants de l'équipement d'origine.

Due to ongoing product improvements, we reserve the right to change design, specifications, and materials without notice.

Debido a las constantes mejoras del producto, nos reservamos el derecho de cambiar diseño, especificaciones y materiales sin aviso.

En raison des améliorations constantes apportées à nos produits, nous nous réservons le droit de changer de concept, de spécifications et de matériaux sans préavis.

ROBINAIR

655 Eisenhower Drive
Owatonna, MN 55060 USA
Tech Services: 1-800-822-5561
Fax: 1-866-259-1241
Customer Service: 1-800-533-6127
Fax: 1-800-322-2890
Web site: www.robinair.com